

TECHNOLOGY EXCELLENCE

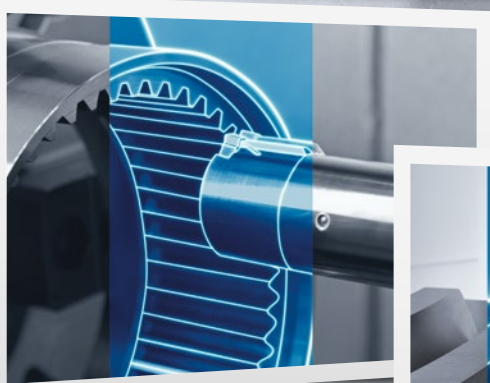

gearSKIVING



gearBROACHING



gearMILL

DM **QP**

DMG MORI QUALIFIED PRODUCTS

GEAR CUTTING –

Complete machining
and technology integration
par excellence



34

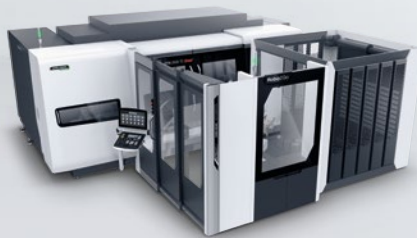

Robo2Go MAX



PH Cell MAX



PH 50



MATRIS Light



18

Thanks to gearMILL gear cutting software, NAMCO Machine & Gear Works produces high-precision gears on standard machines with standard tools, including on a DMC 125 FD duoBLOCK.

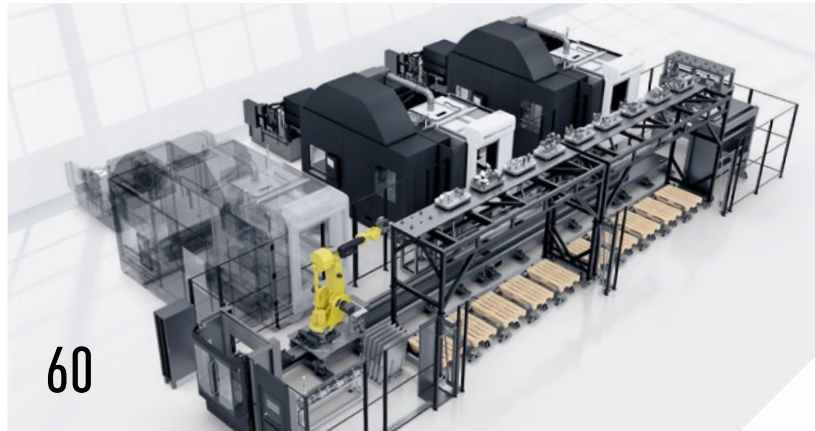

60

Lindner-Recyclingtech GmbH is a global specialist for mechanical recycling, including plastics. The components for the in-house developed cutting blade system are manufactured fully automatically on two DMU 80 P duoBLOCKs, which are automated with a WH Flex.

08 **DMQP/GEAR CUTTING**

- DMG MORI Technology Cycles
- Unique DMG MORI Gear Cutting Solutions
- Maschinenfabrik Mönninghoff GmbH & Co. KG
- NAMCO Machine & Gear Works Ltd.

24 **DMQP/TOOLING**

- Mikron Tool

26 **WORLD PREMIERES**

- NTX 500
- New options for the SPRINT 3218
- DMU | DMC 85 H monoBLOCK
- MS Powertrain Technologie GmbH

34 **AUTOMATION**

- Automation Portfolio
- DMG MORI Retrofit Products
- CNC Grießhaber
- **NEW:** Robo2Go MAX – The Standard Automation
- Heppler GmbH
- **NEW:** MATRIS Light
- PH Cell
- **NEW:** PH Cell MAX
- Mayer Präzision GmbH
- DMG MORI Ultrasonic Lasertec GmbH/ **NEW:** Automation PH 50
- Trützschler Textile Machinery Co., Ltd.
- Lindner-Recyclingtech GmbH
- **NEW:** Automation – DMG MORI Cell Controller

66 **DIGITIZATION**

- VETEC Ventiltechnik GmbH
- Nashero Srl
- Karl Georg Stahlherstellungs- und Verarbeitings GmbH

WORLD PREMIERES 2022

26 **NTX 500**

Turn & Mill complete machining for workpieces up to $\varnothing 90 \times 558$ mm



30 **DMU | DMC 85 H monoBLOCK**

Horizontal universal machining now up to 1,000 kg table load



INNOVATIONS FOR PEOPLE AND THE ENVIRONMENT

DMG MORI

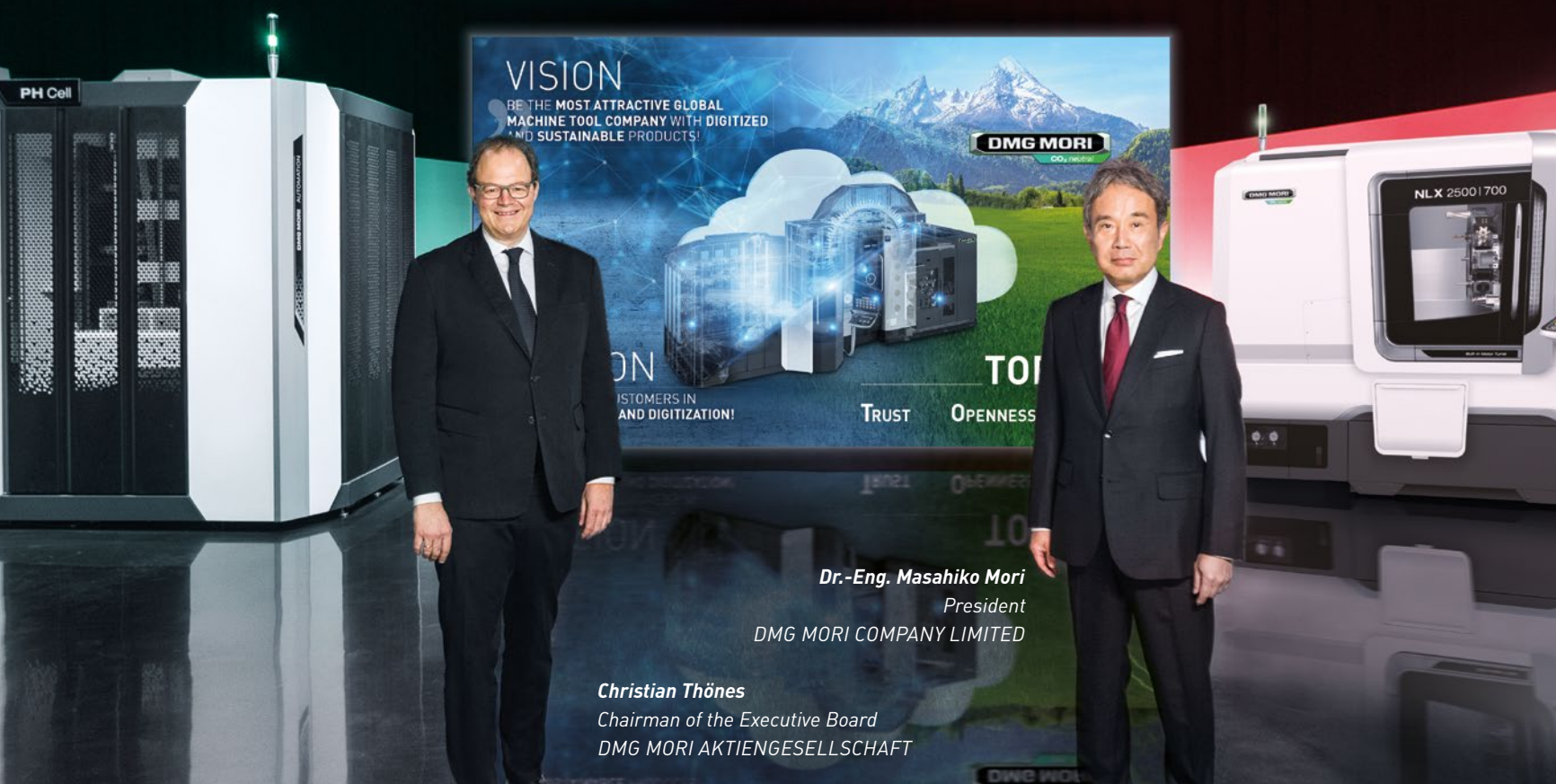

Dr.-Eng. Masahiko Mori
President
DMG MORI COMPANY LIMITED

Christian Thönes
Chairman of the Executive Board
DMG MORI AKTIENGESELLSCHAFT

Dr. Mori, Corona is now entering its third year. How are you dealing with the situation as a company?

Dr. Masahiko Mori: As difficult as it is to deal with the situation personally, you still have to keep your goals as an entrepreneur and the company in focus. A look at the business results shows that we have successfully achieved this at DMG MORI as a Global One Company.

All employees have been working for many months under drastically more difficult conditions than before – and they still deliver proof of their skills every day.

We thank you – and likewise, I want to thank our customers, partners and suppliers. Together we have proven how valuable fair and stable business relationships are. Only the personal relationships that have grown over decades made it possible for phone calls and video conferences to compensate for not being able to meet.

Digitization has helped enormously in this area, and it also showed that the most important things are, were and will be the people we live with and the environment we live in.

... hence the sustainability offensive ...

Christian Thönes: The topic of “sustainability” is part of the DNA of DMG MORI and a common thread running through all our corporate activities. We are making DMG MORI more sustainable – and also our customers, partners and suppliers!

Dr. Masahiko Mori: In doing so, we assume responsibility for resources in a holistic manner. Today, DMG MORI already has both a CO₂-neutral company carbon footprint and a climate-neutral product carbon footprint thanks to the climate triad “avoid – reduce – compensate.”

»

This includes direct and indirect emissions from our own value creation and indirect emissions from upstream processes along the supply chain. Among other things, we also ask our suppliers to become active themselves and, for example, to reduce their CO₂ emissions.

Christian Thönes: All machines delivered anywhere in the world after January 2021 are manufactured in a completely climate-neutral way. DMG MORI thus assumes a pioneering role in the industry worldwide. Out of more than 1,000 applicants, we are among the TOP 17 companies nominated for Europe's largest sustainability award in the field of climate protection. Since September 2021, DMG MORI has also been a certified member of the "Science Based Targets" initiative, whose goal is to limit global warming to a maximum of 1.5 °C. In 2021, we also committed to implementing the Task Force on Climate-related Financial Disclosures (TCFD), thus following the recommendations for voluntary and consistent disclosure of climate-related information.

Speaking of the supply chain, recent studies predict that disruptions in the global economy could continue until the middle of the year. An easing of the situation is currently not in sight, they say. How tense is the situation at DMG MORI?

Dr. Masahiko Mori: Shortages of material and high costs for raw material and transport put a strain on the whole economy. Added to this are the general restrictions due to Corona and increasing inflation. This is something we as a machine tool manufacturer also experience. Nevertheless, thanks to our stable, excellent network of partners and suppliers, we were able to avoid serious interruptions in production and even reduce price adjustments in sales to a minimum. We owe that to our customers.

Christian Thönes: Today we are, on the whole, more innovative, more digital and more resilient in terms of sustainability, from raw materials to recycling, and with a unique future architecture for networked solutions consisting of machines, automation and digitization. This means: DMG MORI is on course.

In particular, many small and mid-size companies face enormous challenges when it comes to digitization. What is your assessment of the digital situation in the manufacturing industry?

Dr. Masahiko Mori: The present shouldn't be measured against a backdrop of exaggerated visions. After around ten years of "Industry 4.0", the entire industry is still in the early stages of what was a scientifically proclaimed industrial revolution with undeniably fascinating possibilities and perspectives that are now gradually becoming concrete and possible to realize.

Christian Thönes: In this respect, DMG MORI is regarded as an "enabler", as a digital pioneer in machine tool manufacturing and production technology. We take responsibility and implement digitization internally in our own production plants as well as externally at our customers. To this end, we offer a comprehensive portfolio of digital products and services for the entire process chain: from planning and work preparation to production, monitoring and service.

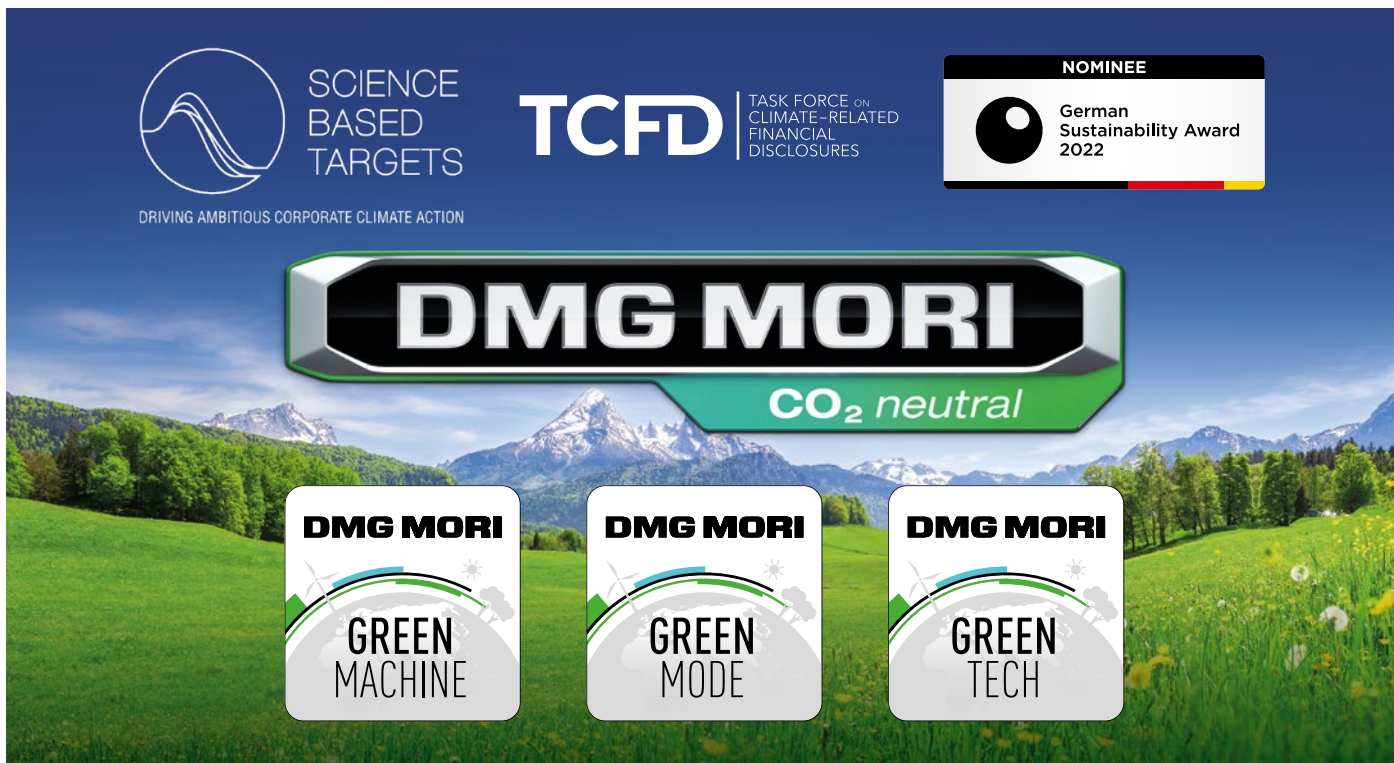

DMG MORI has committed itself to comply with the recommendations of the Task Force on Climate-related Financial Disclosures (TCFD). This goes hand in hand with joining the Science Based Targets Initiative (SBTi), which validates our specific CO₂ reduction targets for meeting the 1.5 degree objective.

No other supplier in the manufacturing industry offers such a broad range and variety. This applies in particular to the integrative interaction of our high-tech machine tools in all sizes and complexities with the current 57 automation solutions for workpiece or pallet handling, including open-interface master computer technology and central tool management. This is unique.

What is DMG MORI highlighting as it enters 2022?

Dr. Masahiko Mori: Last year alone, DMG MORI presented a total of 27 new developments, first and foremost 7 world premieres, 3 new automation solutions and 16 digital innovations, complemented by a new development from the DMG MORI Components sector. We already know that we will be presenting about 40 innovations to our customers this year.

For example, the new NTX 500 for 6-sided turn & mill complete machining of chuck and bar parts up to $\varnothing 90 \times 558$ mm deserves special mention. Highlights are the compactMASTER spindle and, above all, the integrated automation solutions with bar feeders or robots. The manufacturing target group for these all-rounders can be found, among others, in the field of flexible precision machining in the medical sector (hip joints, shoulder implants, bone plates), engine technology (injection nozzles) and precision mechanics (watch cases).

Christian Thönes: A second highlight are the horizontal machining centers DMU 85 H monoBLOCK and the DMC 85 H monoBLOCK version with an integrated pallet changer. Designed for component weights of up to 1,000 kg, the latest innovation in the successful

monoBLOCK series offers maximum process reliability, precision and long-term accuracy thanks to its horizontal gantry concept and inherently rigid machine bed. Meanwhile, linear drives in the X and Z axes as well as direct drive in the C-axis ensure maximum dynamics, while the powerMASTER spindle provides the requisite speed and torque.

With PH Cell MAX, LPP, PH-AGV and WH Flex, flexible automation solutions are also available to meet all customer requirements.

And what is happening in terms of automation?

Christian Thönes: In this issue of our Technology Excellence magazine, we are presenting four innovations early in the year:

»

NTX 500

The solution for the medical industry: Turn & mill complete machining of small workpieces up to $\varnothing 90$ mm in a footprint < 6 m².

DMU | DMC 85 H monoBLOCK
Horizontal 5-axis universal machining – now for workpieces weighing up to 1,000 kg.



→ More about the NTX 500 on page 26



PH Cell MAX

Thanks to the integrated pallet changer with a transfer weight of up to 2,000 kg, the PH Cell MAX is the ideal automation solution for DMU universal machines of the H-monoBLOCK or duoBLOCK series. Retrofittable and with up to 21 pallets in a footprint of 16.5 m².



MATRIS Light

With a footprint of less than 1.4 m² and an installation time of 5 minutes, MATRIS Light is a highly flexible and collaborative workpiece handling system for small workpieces up to 5 kg. It can be retrofitted to over 20 machines with an automation interface.

→ More information on this topic on page 46

- + Robo2Go MAX for automated machining of heavy workpieces: In the most powerful version, the robot is designed for handling components weighing of up to 115 kg and in a diameter range of $\varnothing 40$ to $\varnothing 400$ mm. This makes the Robo2Go MAX the ideal addition to the Robo2Go series and a suitable automation solution for large lathes and turn-mill centers – from the CLX 750 and CTX beta 2000, to the CTX beta 1250 | 2000 TC and the entire CTX gamma series, right up to some NLX and NTX sizes.
- + PH Cell MAX for flexible pallet handling with a transfer weight of up to 2,000 kg: The new PH Cell MAX offers unique flexibility in pallet handling. Designed for machining centers of the DMU | DMC H monoBLOCK and DMU | DMC duoBLOCK series, but with an integrated automation interface, it is a compact and retrofitable automation solution. With space for up to 25 pallets (up to 800 × 800 mm), the PH Cell MAX increases the productivity of any production centre.
- + The cost-effective and compact PH 50 pallet handling system is specifically designed for the production of smaller workpieces. With a footprint of just 2.7 m², the system handles total weights of up to 70 kg. This innovation is therefore tailor-made to work with the milling

machines of the DMP series and the DMU 50 as well as the CMX 50 U and CMX 600 V. The same applies to the ULTRASONIC 50, the LASERTEC 45 and the LASERTEC 50 PrecisionTool.

- + The MATRIS Light is positioned as a compact all-rounder for automated production of smaller batches. The highly flexible robot system can be connected to different machine tools within minutes. Compatible models include NTX and NZX series turn/mill centers, NLX lathes, CMX V series vertical machining centers and i 30 V and NHX 4000 horizontal machining centers.

Dr. Masahiko Mori: I am also particularly proud of the new LPS 4 Cell Controller, with which we have integrated the digital automation of products and processes as well as the digital networking of entire process chains and production networks into manufacturing. As a central component on the shop floor, the new master computer can now manage various pallet and workpiece handling systems, including the control of driverless transport systems (AGVs) for internal logistics. Moreover, thanks to an open DMG MORI API (Application Programming Interface), the LPS 4 Cell Controller can be integrated quickly, easily and, above all, individually into a customer's system or IT infrastructure.

This clearly points the way to digital twins. How has DMG MORI defined this topic for itself?

Christian Thönes: The yardstick for us is practical implementation and a consistent focus on added value for the customer. For us at DMG MORI, "digital twin" always stands for a digital image of machines, automation systems, processes and sequences. As early as in the development phase we use the "digital twin" e.g. to simulate all production processes including work area, automation and all components. This speeds up the process enormously and provides a time advantage of 80% later on during commissioning. In addition, employees can be trained on the "digital twin" of the machine or system prior to installation and NC programs can be prepared perfectly.

Dr. Masahiko Mori: At the moment, we are already preparing the next step. Specifically, the aim is to transfer the level of intelligent virtuality achieved in digital engineering to the practical application at the customer's site. This perspective creates a transparent digital image of the machine and process life cycle.

From this, countless possibilities for optimization of the value-added processes in machine tool manufacturing and production engineering can be derived using human experience and AI tools. Among other things, this bridges the gap to our

sustainability goals downstream, i.e. to a "100 % green machine" over the entire life cycle at the customer's site.

Automation and digitization are often discussed in contrast to the role of humans. Is this also the case at DMG MORI?

Dr. Masahiko Mori: Automation and digitization are tools on the way to maintaining future viability. But manufacturing cannot work without people! How digitization places people at the center and optimizes their interaction with the mechatronic capabilities of the machine tool is demonstrated by our 55 technology cycles for shop floor programming. They show how complexities remain manageable for users and employees due to digital support and how new value can thus be gained for the company.

Christian Thönes: For example, gear cutting has been the exclusive domain of extremely well trained experts with special machines for decades. With 5-axis simultaneous milling and the integration of technologies for turning, milling and (later) grinding, the picture has changed fundamentally. However, gear cutting on standard machines from DMG MORI only became a real revolution with intelligent technology cycles.

With our gearSKIVING, gearMILL and gear-BROACHING technology cycles, a wide variety of gears even of the highest complexity and precision can now be programmed on site directly on the machine. This has simply made gear cutting machines superfluous for a wide range of tasks. That even holds true in retrospect, because a large number of DMG MORI technology cycles are available as retrofit options for many existing machines.

You talk of automation and digitization as "the path to the goal." From this perspective, is the machine merely a "means to an end"?

Dr. Masahiko Mori: A machine tool, together with its inherent manufacturing processes and technologies, is the means to transforming ideas and visions into material innovations. I cannot imagine a more fascinating task than working directly on this source of product creation. It is precisely this fascination that motivates us and our customers around the world to work together to achieve ever higher levels of performance.

In conclusion, can you give us a glimpse of where the digital journey of and with DMG MORI will be heading?

Dr. Masahiko Mori: A lot of information in a process chain is still distributed between data silos within companies. So what the shop floor lacks are open structures and interoperable data interfaces. To this end, we will be able to offer our customers a wide range of products based on our APP-based control and operating system CELOS: For more quality, efficiency, productivity and sustainability.

Digitization increases efficiency, automation increases utilization rates. Obviously, the world of machining will need fewer machine tools in the future?

Christian Thönes: But more and more from DMG MORI! Our vision is to become the most attractive machine tool manufacturer worldwide with digital and sustainable products. And for this we empower our customers – in manufacturing and digitization! Always based on the values of trust, openness and passion and with a high degree of innovative power.

«

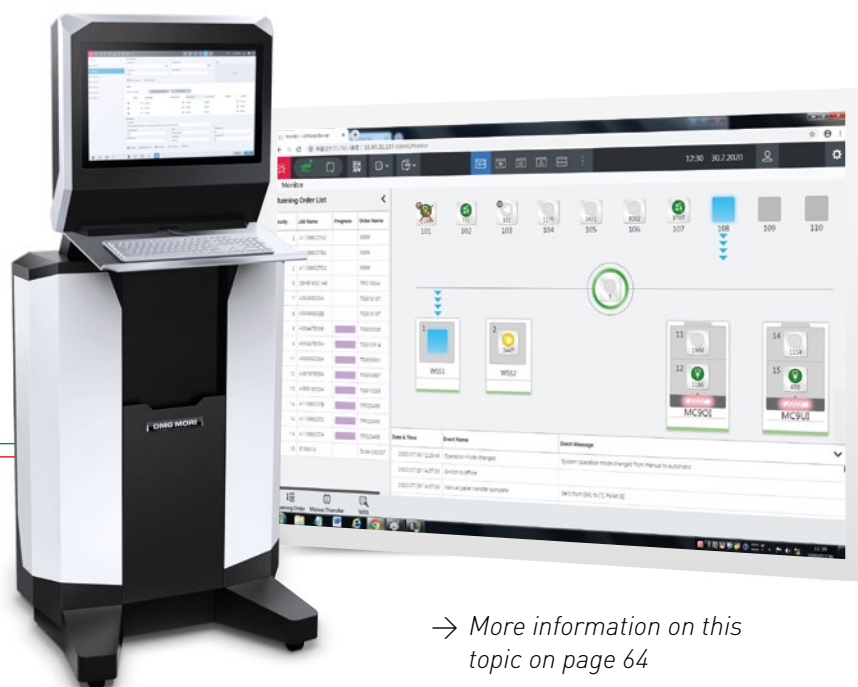

The new DMG MORI Cell Controller LPS 4 combines everything into one – from pallet and workpiece handling to AGV control – with direct interfaces to CELOS, ISTOS PRODUCTION PLANNING as well as ERP and tool management systems.

→ More information on this topic on page 64

UTILIZE YOUR MACHINE'S FULL POTENTIAL

You might well know the problem. You get an enquiry for a range of components that, at first sight, are ideal for your machines. But the devil is in the detail. Special operations are needed, e. g. internal teeth which you are unable to reproduce. You now have to choose whether to turn down the order or buy-in the service from outside. However, this can be avoided by using our exclusive DMG MORI technology cycles. On the following pages, you will find out how to overcome these challenges as well, and increase your own added value with a simple software upgrade.

Gear cutting for all

The manufacture of high-quality precision gears has for decades been the preserve of the absolute specialist, applying to the machine builder as well as to those "indoc-trinated" in the application. However, the picture has changed fundamentally with pioneering innovations such as 5-axis simultaneous machining and the integration of technologies for turning, milling and (more recently) grinding.

55 DMG MORI technology cycles – complex machining implemented with ease

As a pioneer and market leader in these cutting-edge fields of machine tool manufacture, DMG MORI has continuously pushed the boundaries to the point where they become standard. Along with mechanical innovations, increasingly progressive and powerful control systems have characterized the face of machine tool evolution. The practical application of mechanics and electronics have ultimately been completely revolutionized by DMG MORI technology cycles, which presently number 55.

Unique DMG MORI gear-cutting cycles

These digital masterpieces enable a wide range of gears, even those of high complexity and precision, to be programmed directly at the machine. Special gear-cutting machines have therefore simply become unnecessary for a wide variety of tasks. This also applies retrospectively, as many of the DMG MORI technology cycles, particularly the gear-cutting cycles, are available as retrofit options for existing DMG MORI machines.

Conversational programming is 60% faster

Complex NC programs are calculated automatically after entering the gear parameters using menu guidance. This delivers a time saving of up to 60% compared with conventional programming. With gear-BROACHING, gearSKIVING and gearMILL, DMG MORI offers three innovative technology cycles that enable high-accuracy gears to be machined efficiently.

«

55 DMG MORI TECHNOLOGY CYCLES – COMPLEX MACHINING IMPLEMENTED WITH EASE

+ 23 MACHINING CYCLES

e. g. new machining processes and enhanced machine capability such as gear machining

+ 15 HANDLING CYCLES

e. g. simplification of machine operation and automated sequences

+ 9 MEASURING CYCLES

e. g. increased machining accuracy and transparency of QA processes

+ 8 MONITORING CYCLES

e. g. increased machine safety and process reliability

CONVERSATIONAL PROGRAMMING IS 60% FASTER

The exclusive DMG MORI technology cycles are genuine assistive systems for shopfloor programming that boost productivity and safety as well as enhancing machine capability.

+ Clear programming structure

+ Up to 60% faster programming

+ Error reduction thanks to conversational programming

+ New technologies (gear-cutting, grinding)

+ Technology know-how saved in the program

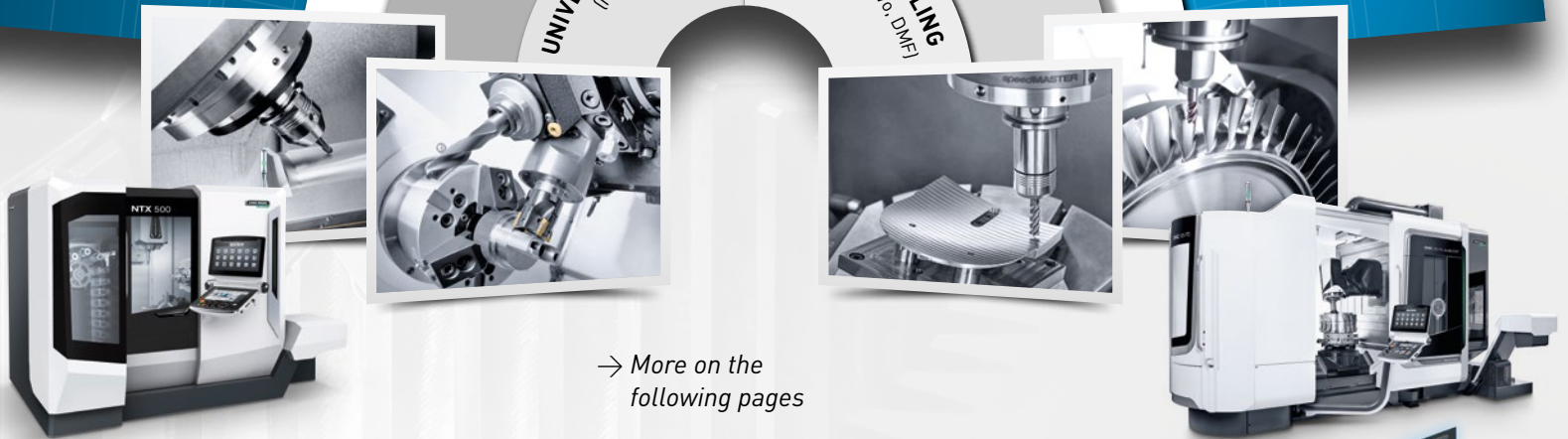
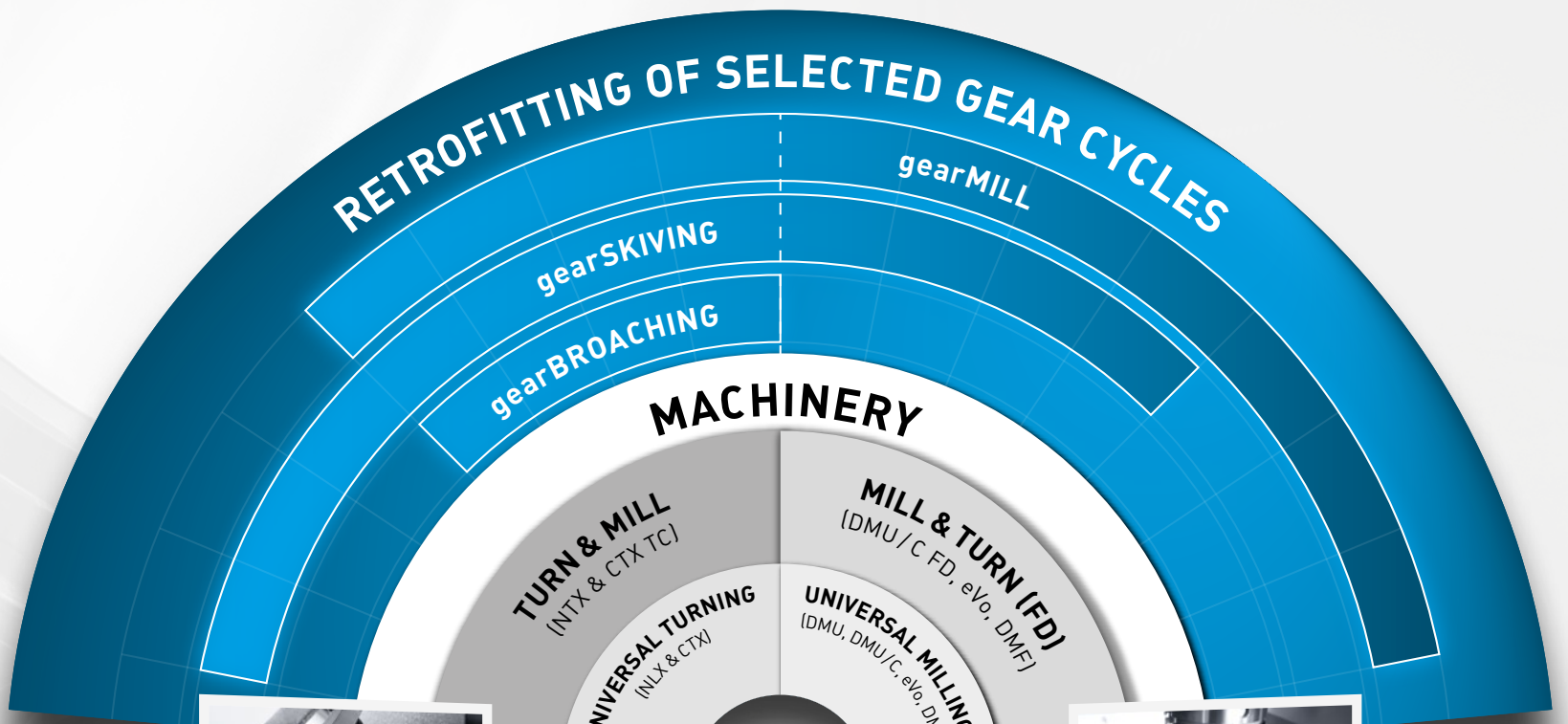

→ More on the following pages

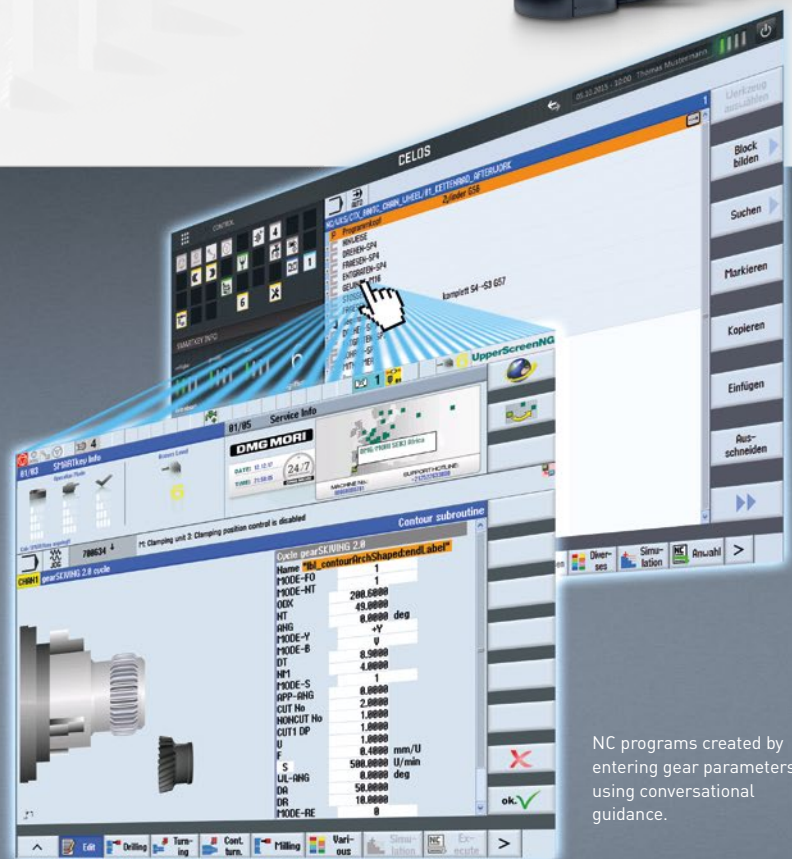
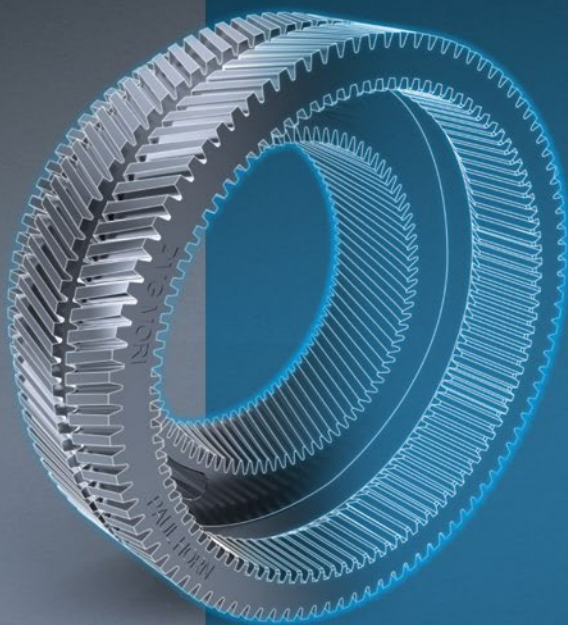

NC programs created by entering gear parameters using conversational guidance.

UNIQUE DMG MORI GEAR CUTTING SOLUTIONS



FEASIBILITY

Feasibility check in **<3 working days**

DELIVERY TIME

Delivery of customized tools from HORN for gearBROACHING or gearSKIVING in **<10 weeks**

gearSKIVING Gear skiving



| Focus machines | Module* | Quality* | Diameter** |
|--|----------|----------|------------------------------|
| NLX/CTX (incl. Y-axis) | ≤ 1.5 | ≥ 9 | max. 150 mm |
| NTX 1000/CTX beta TC | ≤ 2 | ≥ 7 | max. 340 mm |
| NTX 3000/CTX gamma TC | ≤ 4 | | max. 500 mm / max. 530 mm |
| DMU eVo/DMF | ≥ 2/≤ 5 | | max. 800 mm |
| DMU/C FD (monoBLOCK & duoBLOCK & Portal) | ≥ 3/≤ 11 | | max. 3,200 mm |

→ More on gearSKIVING on Page 16

gearMILL Gear milling



| Focus machines | Module | Quality* | Diameter** |
|---------------------------|--------|----------|------------------------------|
| NTX 1000/CTX beta TC | | ≥ 7 | max. 500 mm |
| NTX 3000/CTX gamma TC | | | max. 670 mm / max. 700 mm |
| DMU eVo/DMF | ≥ 3 | ≥ 5 | max. 800 mm |
| DMU/C (monoBLOCK) | | | max. 1,000 mm |
| DMU/C (duoBLOCK & Portal) | | | max. 3,200 mm |

→ More on gearMILL on Page 20

gearBROACHING Gear broaching



| Focus machines | Module* | Quality* | Diameter** |
|-----------------------|---------|----------|------------------------------|
| NTX 1000/CTX beta TC | ≤ 2 | ≥ 9 | max. 500 mm |
| NTX 3000/CTX gamma TC | ≤ 4 | | max. 670 mm / max. 700 mm |

→ More on gearBROACHING on Page 15

* Depending on machine & technology

** Depending on internal or external gear teeth as well as tool dimensions and machine size



Utilize the full potential of your DMG MORI machine – turning, milling and gear cutting on standard machines!

Dr.-Ing. Edmond Bassett
 Engineering Development Manager
 GILDEMEISTER Drehmaschinen GmbH
 edmond.bassett@dmgmori.com

DMG MORI TECHNOLOGY CYCLES

GEAR CUTTING – WE HAVE THE SOLUTION

- + **FAST:**
60% faster thanks to menu-guided entry of gear parameters
- + **SIMPLE:**
Automatic calculation of NC program based on gear parameters
- + **RETROFITTABLE:**
Pure software solution – integration in new and existing machines*

*Retrofitting of gearBROACHING and gearSKIVING depends on control system version

GEAR-CUTTING
 QUALITY
 UP TO > 5

INTERNAL & EXTERNAL GEARS

3,200 mm MAX. DIAMETER

SPUR GEARS

- + Spur, helical and double-helical gears
- + Segments

BEVEL GEARS

- + Spur, helical, spiral and hypoid gears
- + Axis angles other than 90°
- + Klingelnberg Zyκλο-Palloid®
- + Gleason

WORM GEARS

- + Profil ZA
- + Profil ZN
- + Profil ZI

RESILIENCE THROUGH TECHNOLOGY INTEGRATION



Example of various coupling rings, which are used in tooth clutches or tooth brakes, for example.

A close-up photograph of a large industrial gear assembly. The central focus is a dark, cylindrical metal component with a series of three circular holes along its length. This component is meshed with a large, dark-colored gear. To the left, a golden-colored coupling ring is visible, partially overlapping the gear. The background is a blurred industrial setting with various metal parts and structures.

Innovative drive technology from Maschinenfabrik Mönninghoff GmbH & Co. KG has been the benchmark for quality and reliability since 1916. The 125 company employees develop and manufacture a diverse range of couplings, brakes, linear actuators and complete system solutions for customers in almost every sector – from agriculture through robotics to the food industry. After 105 years at the original location in Bochum, Mönninghoff has now built a new, modern plant to ensure the continuation of optimal operation along the entire process chain. In production, the company has been relying on machine tool technology from DMG MORI since 2010. Further investments in machining centers and turning machines followed the installation of an NT 4300. The latest acquisition is a CTX beta 800 TC with Robo2Go. Mönninghoff also uses numerous DMG MORI technology cycles for their gear production.

Design and manufacture of complex drive components

“The structural transformation in the Ruhr district over the last few decades meant we had to come up with something new,” explains Charlotte Finger, managing partner of Mönninghoff. Until the 80s, the company had generated over 90 percent of its sales in mining. Since then, it has continued to develop a special niche in drive technology.

»

gearSKIVING a coupling ring made of a special bronze alloy on the CTX beta 800 TC.

After Mönninghoff had outsourced special gear manufacturing to another firm – Chemnitzer Zahnradfabrik – in 1992, the company was free to concentrate on its core expertise: The design and manufacture of sophisticated and complex coupling and braking systems. “These are almost exclusively special solutions, which we often develop in cooperation with our customers,” explains Charlotte Finger. Mönninghoff is well known throughout industry for this expertise and is generally involved in project developments at an early stage. For a long time now, the company has not considered itself simply a supplier but rather a technology partner for its customers.

Robo2Go: Multi-machine operation and consistent quality in 3-shift operation

While Mönninghoff is preserving this specialist expertise for future generations by

in-house training, with currently six junior trainees employed, the focus is also on continuous modernization of production. The proof lies in regular investment in CNC technology from DMG MORI – the latest being a CTX beta 800 TC with Robo2Go. Timon Lubek, head of production, explains the reason behind the acquisition: “Our goal is to achieve the highest possible machine utilization across all three shifts. Supported by the Robo2Go, our team is even able to operate several machines at the same time.” It offers easy handling and is the ideal automation for medium-size batches. Timon Lubek considers quality to be another argument in favor of automated manufacturing: “As manual reclamping is no longer necessary, it is easier to achieve accuracies down to tens of microns.” Components made of different materials including steel, aluminum and bronze are part of the daily work.

Automation and Technology Cycles from DMG MORI

Maschinenfabrik Mönninghoff is taking new initiatives in its manufacturing together with those who ultimately work with the modern technology. Timon Lubek says: “It is important to include in purchasing decisions the employee who is to be responsible for operation, as the person can contribute their experience and are in a position to recognize the added value quickly.” This was the case with the Robo2Go and applies equally to the subject of technology integration.

Mönninghoff makes use of a range of DMG MORI Technology Cycles, which enable special processes such as gear cutting to be carried out on conventional CNC machine tools.



The Robo2Go stacking magazine offers sufficient capacity to enable around-the-clock production with the CTX beta 800 TC.

AUTOMATION
SOLUTION AND
TECHNOLOGY
INTEGRATION ARE
THE IDEAL
WAY FOR US TO
SUSTAINABLY
INCREASE OUR
CAPACITY.

Optimal machine utilization thanks to gear cutting cycles from DMG MORI

“Our coupling components all have different gear teeth, which used to be manufactured using special gear cutting machines,” explains Timon Lubek. “The Technology Cycles from DMG MORI allow us to machine the same products, switching rings for example, on conventional turn-mill centers like the CTX beta 800 TC to the same quality on the same machine and sometimes even faster. The experience of the Mönninghoff specialists has repeatedly been incorporated into the continued development of the Technology Cycles. Manufacture of gear components now only requires a maximum of two clampings.

»



The gear cutting cycles from DMG MORI now enable us to completely machine our workpieces on one machine, even faster and to the same quality as on our special machines.

*Charlotte Finger, managing partner with
Timon Lubek, head of production
Maschinenfabrik Mönninghoff GmbH & Co. KG*

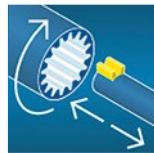
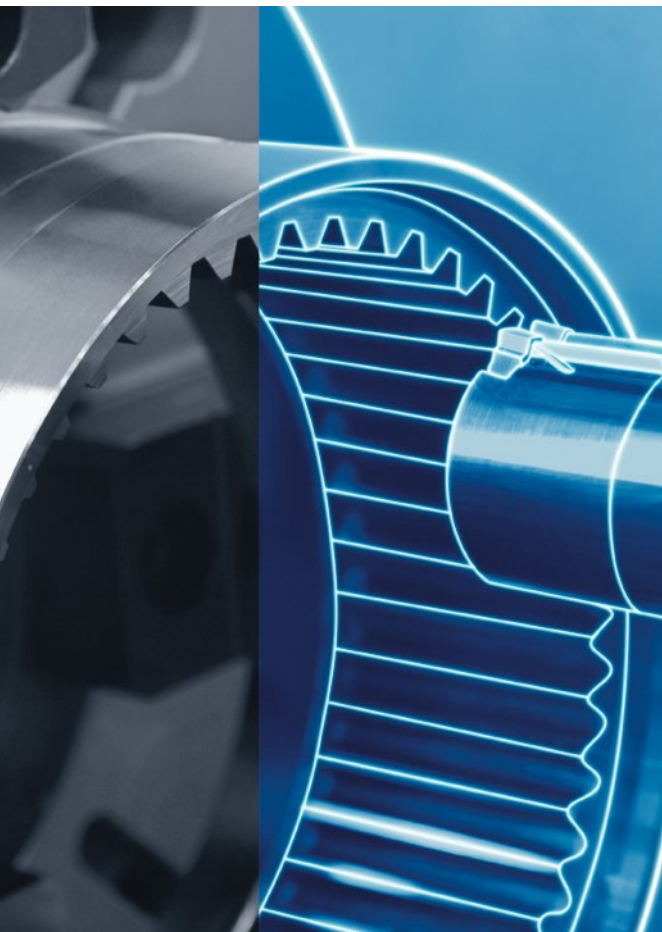

gearBROACHING
EXCLUSIVE TECHNOLOGY CYCLE

MACHINING OF GEARS AT THE MAIN AND COUNTER SPINDLES

- + Internal and external gears
- + Ideal for workpieces with shoulders or interference contours due to runout
- + Compensation parameters for deflection of the tool holder
- + Available for machines with SIEMENS/CELOS with SIEMENS



ph HORN ph

DM(QP)
DMG MORI QUALIFIED PRODUCTS

- + Single-tooth to four-tooth cutting tools with clear tool definition
- + High productivity in combination with broaching attachment
- + Tools up to module 4



CTX beta 800 TC

- + **100 % TURNING:**
Workpieces up to $\varnothing 500 \times 800$ mm
- + **100 % MILLING:**
compactMASTER up to 20,000 rpm and 120 Nm
- + **100 % TOOLS:**
For up to 80 tools

Robo2Go

- + Rapid changeover from chuck to shaft part tray
- + Load capacity 12, 25 and 35 kg
- + Shaft $\varnothing 25 - 150$ mm,
Chuck parts $\varnothing 25 - 170$ mm
- + Workpiece teaching in < 15 min

→ *More information on page 40*

This results in shorter throughput times, reduced internal transportation and less waiting time. The high flexibility is another benefit: "If there are times we don't need to produce gears, the machine can be used for other purposes to make sure it's utilized in the best way possible."

gearSKIVING 2.0 and DMQP tools from Horn

gearSKIVING 2.0 is one Technology Cycle that Mönninghoff uses intensively. It can be deployed to manufacture straight and helical external or internal spur gears, splines and also herringbone gears on turn-mill centers. The cycle controls the synchronization and the tool path. "This makes us ten times faster than when broaching," adds Timon Lubek. He points out the tools they use are from Horn. The tool manufacturer is a long-term and DMQP-certified technology partner of DMG MORI. Crown gears are also

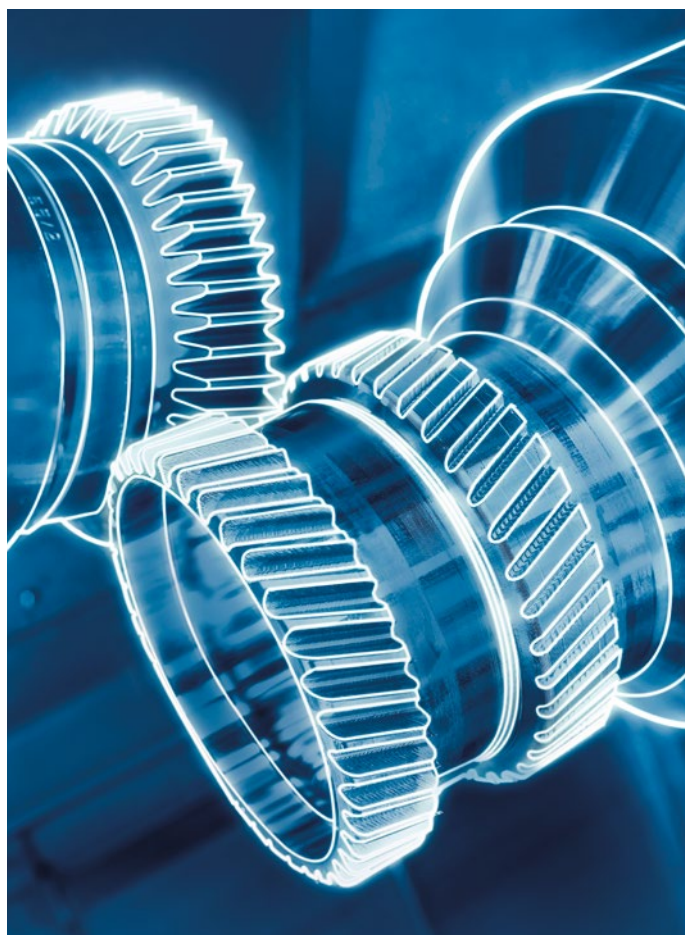

gearSKIVING EXCLUSIVE TECHNOLOGY CYCLE

UP TO 8 TIMES FASTER THAN GEAR SHAPING

- + Straight and helical external or internal spur gears and splines
- + Internal teeth possible without an angle head
- + Synchronization and tool path controlled by the cycle
- + Available for machines with SIEMENS/CELOS with SIEMENS and MAPPS/CELOS with MAPPS
- + **TURN & MILL and DMF**
 - Herringbone teeth with offset*
 - Crown gears by mathematical transformation of the 6th virtual axis* on TC & DMF machines

*NTX & CTX TC with counter spindle and SIEMENS

manufactured by fly cutting on turn-mill machines such as the CTX beta 800 TC. The automatic calculation of the tool path is taken care of by the crownHOBBING Technology Cycle, which DMG MORI implemented in a second phase. Gear shaping takes place in a third phase using the gearSHAPING Technology Cycle. Timon Lubek adds: "Automation solutions make 6-sided complete machining of components like these easier. It also enables quality control to be integrated right from the first component."

The integration of technology is very important to Mönninghoff. This is the reason why Timon Lubek values the long-term partnership with DMG MORI: "In order to be even more successful, we use practically every technology cycle that provides us with added value in programming and machining – from gear cutting and generation through to broaching and grinding. And in cases where

this isn't enough, we jointly develop new bespoke cycles that enable us to machine our special components, or make it easier to do so." The company would like to maintain this in the future, not only to ensure it can manufacture efficiently, but also to be a technology leader. Charlotte Finger also sees a lot of potential in the new manufacturing possibilities: "Automation solutions and technology integration are the ideal way for us to sustainably increase capacity and thus keep our production site in Germany competitive."

MASCHINENFABRIK MÖNNINGHOFF FACTS

- + Founded in Bochum in 1916
- + 125 employees
- + Development and manufacture of clutches, couplings, brakes, linear actuators and complete system solutions
- + Customers include those from agriculture, robotics and the food industry

Mönninghoff

Maschinenfabrik
Mönninghoff GmbH & Co. KG
Burgstraße 35
44867 Bochum, Germany
www.moeninghoff.de

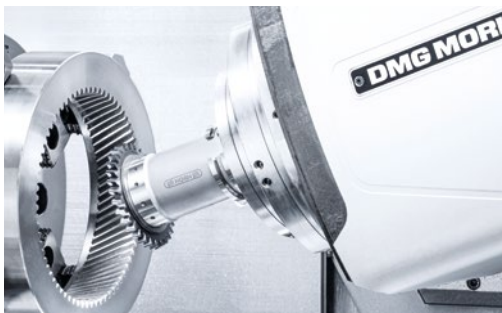

TURN & MILL
Gears up to module 4
(e. g. NTX 3000 or CTX gamma TC)



MILL & TURN
Gears up to module 11
(e. g. DMC 80 FD duoBLOCK)



- + Solid carbide tools and interchangeable insert systems
- + Version with internal coolant supply
- + Tools from module 0.2 to module 8

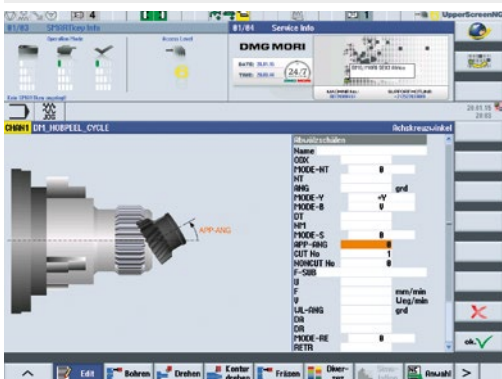

External gears
1. Conversational input of all necessary gear data.

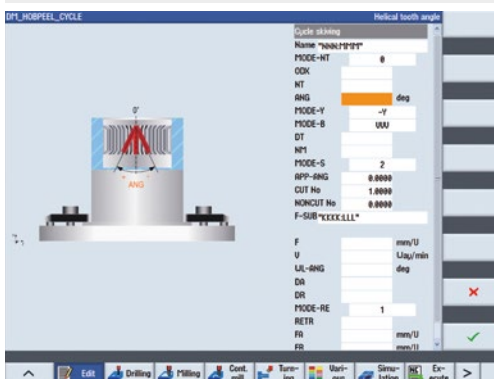

Internal gears
2. The technology cycle automatically creates the NC program

PRECISION GEARS FROM A SINGLE SOURCE



Thanks to gearMILL gear cutting software, we can now manufacture our special solutions quickly and, above all, easily. And thanks to the mill & turn technology on the DMC 125 FD duoBLOCK, we achieve high precision in one clamping. In combination with the grinding machines from TAIYO KOKI, it is an unbeatable overall package.

Bernard Vukovic
 Managing Director
 NAMCO Machine & Gear Works Ltd.

NAMCO was founded in 1976 to serve the growing demand for precision machine components, custom gears and transmission technology. With locations in Edmonton, Canada, and Chardon, Ohio, the company employs more than 75 skilled workers who manufacture reliable and economical products for customers in the paper, oil & gas, mining, and other industries. Since 2019, NAMCO has now invested in 15 CNC machines from DMG MORI, including a DMC 125 FD duoBLOCK for gear milling with gearMILL and two TAIYO KOKI machines for grinding.

Everything from a single source as a success factor

From engineering and design of the products to complete manufacturing, assembly and extensive testing procedures, NAMCO combines the entire process chain under one roof. "In this way, we have quality completely in our own hands and can react flexibly to the respective demand," explains Bernard Vukovic, Managing Director of NAMCO. He adds that the range of services includes both gears produced in large series and individual special solutions. "The challenge is to deliver on time and offer competitive prices."

»

Left picture: Bernard Vukovic in front of a large parallel shaft gearbox.



The NAMCO site in Edmonton, Canada. A second location is in Chardon, Ohio/USA.

DMC 125 FD duoBLOCK

5-AXIS MILL-TURN COMPLETE MACHINING

- + 500 rpm Direct Drive table for 5-axis milling and turning in one clamping
- + Workpieces up to $\varnothing 1,250 \times 1,600$ mm and 2,000 kg
- + powerMASTER motor spindles up to 430 Nm and 52 kW
- + 5X torqueMASTER spindle with 1,800 Nm and 52 kW
- + CELOS with SIEMENS and CELOS with HEIDENHAIN





On the DMC 125 FD duoBLOCK, NAMCO produces gears that are programmed with the DMG MORI software gearMILL, as well as other complex workpieces.

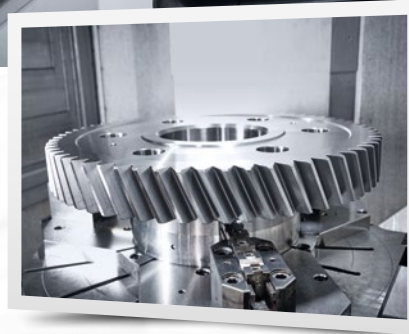

Strong partnership with DMG MORI

To be competitive on the production side, NAMCO relies on state-of-the-art CNC technology from DMG MORI. Bernard Vukovic explains the high investment volume in the past three years with the need to expand production capability: "On one hand, we need innovative machining technologies to manufacture efficiently and in the required quality, and on the other hand, it was a matter of increasing capacity." In DMG MORI, they found a strong and reliable partner to achieve these goals, he said. "The versatile CNC machines allow us to manufacture even more products economically."

DMC 125 FD duoBLOCK: High-precision complete machining in one set-up

The versatility of DMG MORI machines is reflected in one of NAMCO's core areas, gear cutting. There, the team relies on a DMC 125 FD duoBLOCK with the exclusive DMG MORI gearMILL gear cutting software. "Especially for large gears, prototypes and



EXCLUSIVE TECHNOLOGY CYCLE gearMILL

GEAR MILLING ON STANDARD MACHINES WITH STANDARD TOOLS

- + Program creation based on part drawings or gear data
- + Contact pattern individually modifiable
- + Post processor for SIEMENS, HEIDENHAIN and MAPPS
- + Interface for coordinate measuring machine (Klingenberg, Leitz, Zeiss)
- + SPUR GEARS: Straight, helical and herringbone gears, segments
- + BEVEL GEARS: Straight, helical, spiral and hypoid gears, shaft angles not equal to 90 °, Klingelnerberg Zyκλο-Paloid® and Gleason
- + WORM GEAR: Profile ZA, ZN and ZI

special solutions, we have a very effective solution on our shop floor,” finds Bernard Vukovic. The mill & turn center with pallet changer allows setup to take place during machining and is designed for high-precision

gearMILL – IDEAL FOR LARGE GEARS, PROTOTYPES AND SPECIAL SOLUTIONS

complete machining of rotationally symmetrical components up to $\varnothing 1,250$ mm in diameter – including 5-axis milling and turning. Since everything is done in one setup, errors due to manual reclamping operations are eliminated.

»



For smaller special gears, NAMCO uses, among other things, a DMU 65 monoBLOCK, which is automated with a PH 150.

Simple creation of the NC program by entering the gear parameters.

CAM programming, post processors and simulation of the NC program.

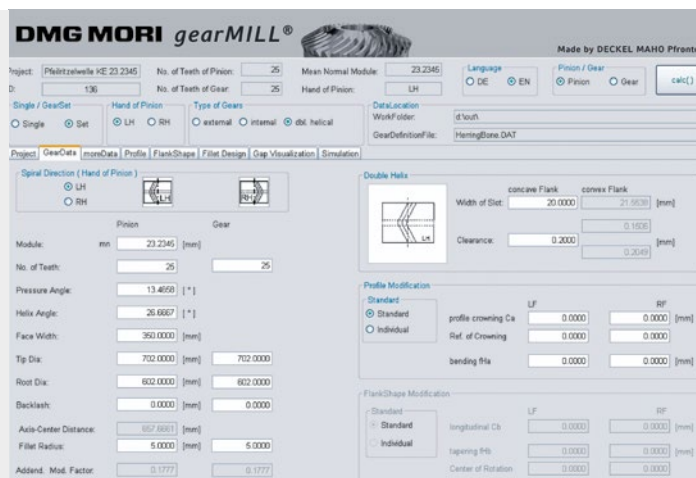

In-process measuring, tactile using a measuring probe and NEW: optically using a laser scanner – accuracy similar to that of a coordinate machine.



ph HORN ph

DMQP
DMG MORI QUALIFIED PRODUCTS

- + Solid carbide tools and interchangeable insert systems
- + Version with optional coolant supply
- + Tools for all module sizes



For the finishing process, NAMCO uses among other machines a CVG 13. Large components with a diameter of up to 1,300 mm are ground.

With gearMILL, technology integration on the DMC 125 FD duoBLOCK goes one step further. gearMILL enables soft and hard machining on one machine and offers quality inspection during the process. In this way, different gears can be produced, and in qualities up to DIN 5 for bevel gears and DIN 6 for cylindrical gears. gearMILL is machine-independent, as it is stand-alone software that can generate NC programs for almost all lathes and milling machines. The program is created on the basis of drawings or gear data. "The solution is extremely economical for us because we can work with standard tools and at the same time have maximum flexibility because we don't need any special machines for the prototypes or special solutions," judges Bernard Vukovic. "We just enter the gear parameters and the software throws up the appropriate NC program." Even contact pattern adaptations are possible without any problems, he adds.

Thanks to the high precision of the DMG MORI machines, reworking is already reduced to a minimum. The final fine-tuning is then achieved by the two TAIYO KOKI, with up to 1.2 μm concentricity and up to Ra 0.17 μm .

Bernard Vukovic
Managing Director
NAMCO Machine & Gear Works Ltd.



High-precision components are essential for NAMCO gearboxes. Thanks to the grinding process, surface qualities of up to Ra 0.17 µm are achieved

OVER 550
MACHINES
INSTALLED
WORLDWIDE



TAIYO KOKI HIGH PRECISION VERTICAL GRINDING

CVG

2 grinding spindles for internal, external and CAM machining
ø from 300 to 1,300 mm

Planetary gear wheel
ø 430 × 235 mm
SNCM420
Ra 0.17 µm
1.2 µm roundness

1.2 µm
roundness



Ra
0.3 µm

Face coupling
ø 700 × 42 mm
SCM420
Ra 0.3 µm
4 µm roundness



TAIYO KOKI:

High-precision vertical grinding

The high precision of DMG MORI machining centers significantly reduces the amount of finishing work required. Nevertheless, NAMCO relies on high-performance grinding machines, which the company also found in the DMG MORI Group. The CVG-13 from TAIYO KOKI is a vertical multi-process grinding machine with pallet changer. Its grinding spindle has a speed of up to 9,000 rpm. "With it, we can grind both inner and outer diameters as well as surfaces – completely in one clamping," Bernard Vukovic describes the added value. The maximum grinding diameter is ø1,300 mm, the workpiece height is 700 mm, and the maximum workpiece weight is 3,000 kg. For smaller workpieces, NAMCO has installed an IGV-3N with a grinding diameter of 250 mm and a workpiece height of 300 mm. Here, the maximum speed of the grinding spindle is 18,000 rpm.

For Bernard Vukovic, this is another gain in flexibility: "This way, we also benefit from grinding a wide variety of components."

The good cooperation with DMG MORI makes Bernard Vukovic optimistic about continuing the partnership. He sees NAMCO in an excellent position for future challenges: "After the opening of our site in Ohio, the expansion of our product portfolio and the modernization of our manufacturing, we have created a good basis for continuing to grow sustainably."

NAMCO MACHINE & GEAR WORKS FACTS

- + Founded 1976
- + A total of 75 employees at the headquarters in Edmonton, Canada and at the Chardon, Ohio site
- + Manufacturing of precision components, gears and drive technology
- + Customers from the Oil & Gas, Mining, Pulp/Paper, Environmental, and other industries



NAMCO Machine & Gear Works Ltd.
9168 – 35 Avenue
Edmonton, Alberta, Canada
www.namco.ca



«

FULL SPEED AHEAD FOR MEDICAL ENGINEERING – NO SPEED LIMIT WITH MIKRON TOOL

Joint projects implemented by DMG MORI and Mikron Tool in the medical engineering sector have clearly highlighted that, as well as the choice of machine, having the right tools is essential. This know-how plays an important role, particularly in the DMG MORI Medical Excellence Centers (in Seebach, Wernau, Chicago and Shanghai). This is where integrated technology solutions are developed together with customers, effective automation processes for maximum quality and autonomy are defined, and digitized processes are ensured. Relevant peripheral and technology accessories from the DMG MORI Qualified Product Program (DMQP) are used in a targeted way. As a DMQP partner in the area of precision tools for micromachining, Mikron Tool makes repeated contributions to groundbreaking innovations.

DMG MORI Medical Excellence Center and Mikron Tool Technology Center

The application-specific technology solutions developed by the DMG MORI Medical Excellence Center primarily involve the realization of the most efficient production processes for the customer. This is why the Medical Excellence Center has been collaborating with experts from the R&D department at the Mikron Tool Technology Center regarding tooling issues for more than six years. Production of the handle for biopsy forceps shows the importance of choosing the correct tool. The cycle time for machining this stainless steel component (in this case 1.4021/X20Cr13) was reduced by more than 40 percent using Mikron Tool tools on a DMP 70 – while adhering to all drawing tolerances and providing excellent surface quality ($R_a = 0.2 \mu\text{m} / R_z < 0.7 \mu\text{m}$).

Various milling cutters from the CrazyMill Cool series are responsible for saving time when producing this component. The special

CrazyMill Cool Plunge & Slot high-performance cutter deserves special mention, as it combines drilling and milling and is characterized by having five times higher cutting

14 TIMES
GREATER METAL
REMOVAL RATE

data and service life that is five times longer. The “Crazy” result: a metal removal rate that is up to 14 times higher than that of the milling cutter previously used.

50 times more coolant – thanks to the unique cooling system

A CrazyDrill SST-Inox 1K with integrated cooling is used for drilling the hole in the lower area of the handle. Its geometry is

Perfect Fit: Experts from the Mikron Tool Technology Center and the DMG MORI Medical Excellence Center. We implement integrated manufacturing strategies for our mutual customers.

Dr. Alberto Gotti
Head of Research and Development
at Mikron Tool





DMP 70: Machined handle of biopsy forceps made from martensitic chromium steel (1.4021/X20Cr13). The CrazyDrill SST-Inox IK is used for drilling the hole.

CrazyMill Cool, carbide milling cutter with integrated cooling in the diameter range from 0.3mm to 8mm.

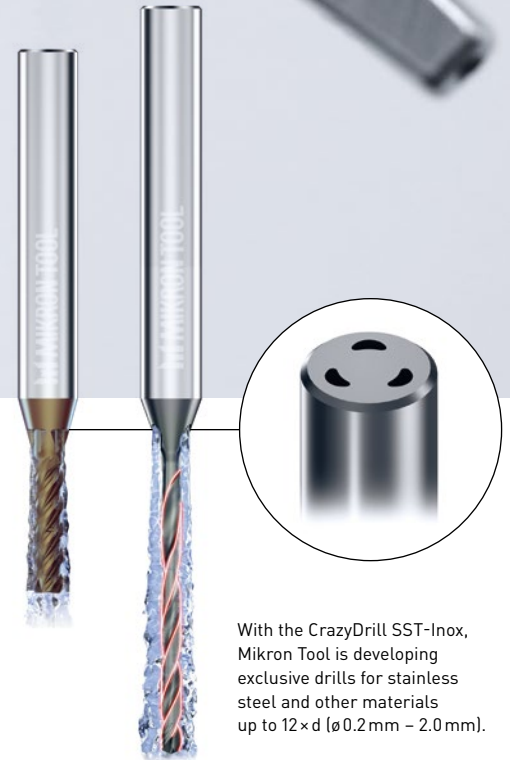

With the CrazyDrill SST-Inox, Mikron Tool is developing exclusive drills for stainless steel and other materials up to 12 x d (ø0.2mm – 2.0mm).

considerably different from the current standards. The innovation lies in the digressive helical flute (patented), which is responsible for efficient chip removal. The unique cooling system delivers 50 times more coolant to the tool tips compared with normal commercial drills, which do not have integrated cooling channels. "In contrast to an external coolant jet, we achieve consistent cooling of the cutting edges with no temperature shock, which leads to longer service life," explains Dr. Alberto Gotti, Head of Research and Development at Mikron Tool.

Efficiency – 10 times faster machining and 15 times longer life with the same tool with increased process reliability

Thanks to these characteristics, the speed of the tool is not limited: Drilling is more than ten times faster as standard – with a tool life that is 15 times longer, plus improved process reliability and precision. The result is a significant reduction in the cost of manufacturing. This is an enormous advantage for cutting tools used in the growing medical sector. Particularly in conjunction with high-precision and dynamic machines such as the DMP 70, these advantages can be exploited in production.

Holistic customer support from Mikron Tool and DMG MORI

The dynamic machining centers from DMG MORI have all of the prerequisites for using tools from Mikron Tool to the full and getting the best out of them. The Mikron Tool Technology Center and the DMG MORI Medical Excellence Center do not only provide high-performance tools, but also integrated manufacturing strategies that include recommendations for the machine, tools, tool holders, workholding and CAD/CAM programming. This means that customers can operate with complete safety, even if they "don't stick to the speed limit."

«



Review of the Medical Day at Mikron Tool on 4 September 2020:
<https://www.youtube.com/watch?v=1i9D7Hufyqk>



MIKRON TOOL FACTS

- + Established in 1998 as a spin-off from the cutting tools department at Mikron SA Agno
- + CrazyDrill, the fastest small drill in the world, was introduced in 1999
- + Mikron Tool created a milling milestone with CrazyMill Cool micro-milling cutters in 2013: Thanks to integrated cooling, materials such as titanium or CrCo that are difficult to cut can be machined up to 20 times faster



Mikron Switzerland AG
 Agno, Tool Division
 Via Campagna 1, 6982 Agno
 Switzerland
www.mikrontool.com



WORLD
PREMIERE
2022

NTX 500

42,000 rpm compactMASTER
TURN & MILL SPINDLE FOR HIGH SPEED
AND MICRO MACHINING

HIGH
PRODUCTIVITY
WITH SMALLEST
FOOTPRINT IN
ITS CLASS



- + **6-sided complete machining**
at main and sub spindle with 8,000 rpm
- + **Workpieces up to \varnothing 120 mm and 558 mm long,**
bar machining up to \varnothing 40 mm
(Workpieces up to \varnothing 90 mm and 558 mm turning
length: when machining with lower turret)
- + **High-speed turn & mill spindle compactMASTER,**
up to 42,000 rpm (30,000 rpm as standard),
incl. 150 mm Y-axis
- + **38-pocket tool magazine**
(Capto C4/HSK-T40/KM40), optional 76 or 114
- + **4-axis machining by lower 16-station turret**
BMT 42/64 with 12,000 rpm
- + **60 mm Y-axis for the lower turret**
- + Automation, e.g. **integrated bar loader and**
robot (IMTR – In Machine Traveling Robot)
- + **CELOS with MAPPS on FANUC or CELOS**
with SIEMENS

Designs and specifications
are subject to changes
without notice.

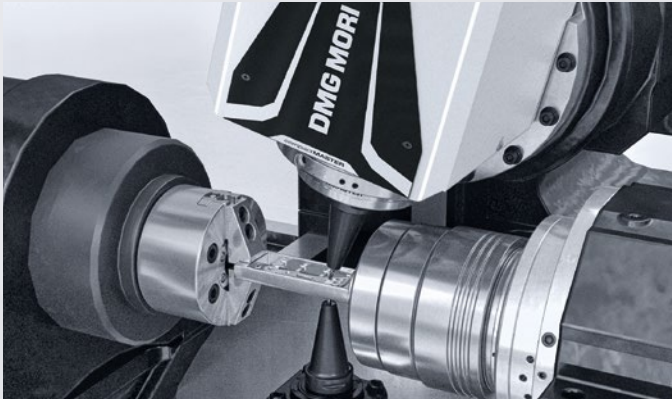

FULL UTILIZATION OF TOOLS IN UPPER SPINDLE AND LOWER TURRET

Direct Drive B-axis with $\pm 120^\circ$ allows 5-axis machining at main- and sub-spindle while lower turret is machining simultaneously.

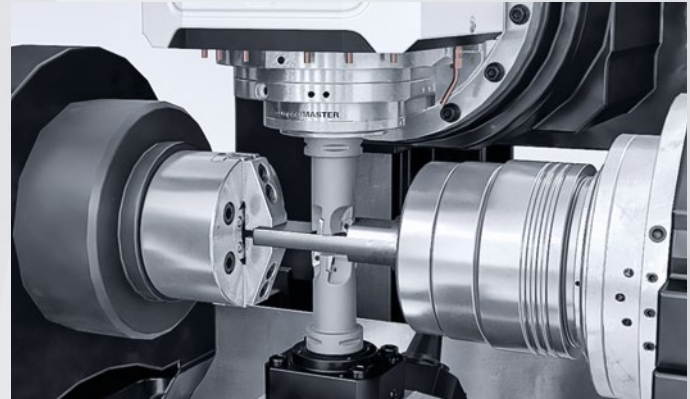

BALANCED CUTTING

Minimize cycle time through parallel machining with upper spindle and lower turret. In addition to 150 mm standard Y-axis stroke of turn-mill spindle, lower turret offers a Y-axis stroke of 60 mm.

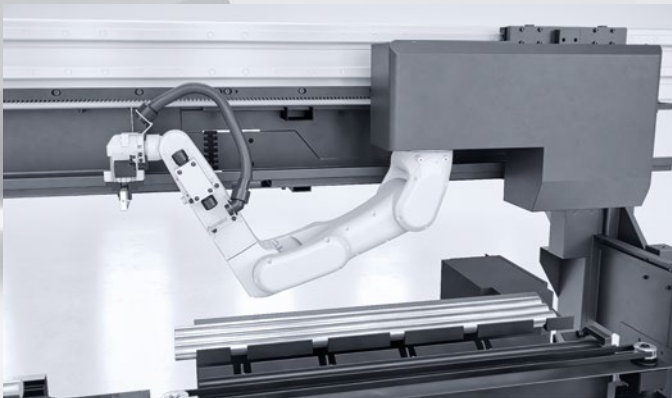

INTEGRATED ROBOT (IMTR)*

Automatic unloading of workpieces from the main or sub spindle.

*Option



INTEGRATED BAR LOADER*

Bar stock up to $\varnothing 40$ mm and 1 m in length.

*Option



DIE & MOLD
PUNCH DIE

Dimensions: $\varnothing 30 \times 150$ mm
Material: SKD11



AUTOMOTIVE
INJECTOR NOZZLE

Dimensions: $\varnothing 30 \times 80$ mm
Material: Tool steel



LIFESTYLE
WATCH CASE

Dimensions: $\varnothing 50 \times 10$ mm
Material: Stainless steel



MEDICAL
BONE PLATE

Dimensions: $\varnothing 20 \times 60$ mm
Material: Titanium

SPRINT 32|8

4 NEW OPTIONS, MACHINE MORE COMPLEX COMPONENTS FASTER

5-axis machining

→ Up to 2× B axes

- 1** + Max. 5 live tools for front machining
- 2** + Max. 4 live tools for back machining

3 More tools – 28+10
→ Option 25 mm bar capacity

4 Big bore spindle
→ $\varnothing 38$ mm bar capacity

2 B-AXIS SUB SPINDLE

4 $\varnothing 38$ mm BIG-BORE SPINDLE



| | | SPRINT 32 8 | | |
|---------------------------|---|-------------|----------|----------|
| | | Option 1 | Standard | Option 2 |
| Max. bar diameter | # | 25 | 32 | 38* |
| Max. number of tools | # | 38 | 28 | 28 |
| Max. number of live tools | # | 16 | 10 | 10 |
| Option B-axis | | | | |
| For main spindle | | ✓ | ✓ | ✓ |
| For sub spindle | | ✓ | ✓ | ✓ |

*35 mm with SWISSTYPEkit

1 B-AXIS
MAIN SPINDLE

3 MAX. 38
TOOLS (+ 10)

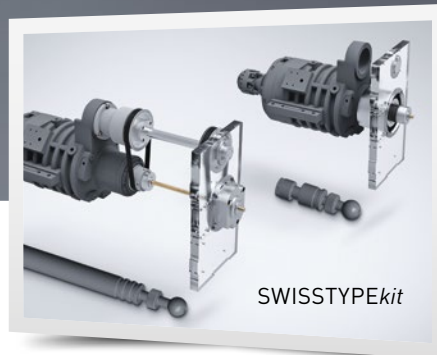

SWISSTYPEkit

SWISSTYPEkit –
FIXED- AND SLIDING-HEAD
TURNING ON THE SAME MACHINE

- + <30 min. changeover time between fixed- and sliding-head turning, incl. installation and changeover of the control system
- + SPRINT 32|5 and SPRINT 32|8: extended spindle stroke from 100 to 240 mm



FIXED-HEAD TURNING

**FITTING/
HYDRAULICS**

Dimensions: ø30 x 80 mm
Material: Stainless steel



**SLIDING-HEAD TURNING
WITH SWISSTYPEkit**

**GEAR SHAFT/
AUTOMOTIVE**

Dimensions: 25 x 110 mm
Material: Stainless steel

Our new SPRINT 32|8 options maximize the flexibility and productivity of your production. Up to 2× B axes for complex machining at the main and sub spindles, 38 mm big bore spindle for larger workpieces and up to 10 additional tools for even more complex parts or sister tools.

Mirko Passerini
Managing Director
GILDEMEISTER Italiana



**WORLD
PREMIERE
2022**

DMU | DMC 85 H monoBLOCK

HORIZONTAL UNIVERSAL MACHINING
NOW UP TO 1,000 kg CAPACITY



**ONLINE MACHINE
CONFIGURATOR**

With just a few clicks to your
individual machine solution:
<https://configure.dmgmori.com>



The free chip removal of horizontal machining is ideal for automated and process-reliable production.

| | DMU 65 H | DMC 65 H | DMU 85 H | DMC 85 H |
|-----------------------|----------------|----------------|------------------|----------------|
| Travel | 650/950/700 mm | | 850/1,150/900 mm | |
| Max. workpiece size | ø 840 × 770 mm | ø 630 × 700 mm | ø 1,040 × 870 mm | ø 830 × 800 mm |
| Max. Workpiece weight | 600 kg | 600 kg | 1,000 kg | 800 kg |



With the H monoBLOCK series we meet the needs of our customers in terms of flexibility, process reliability and automation – with the size 85, we are now extending these advantages upwards.

Cornelius Nöb
Managing Director
DECKEL MAHO Pfronten

FLEXIBLE AUTOMATION SOLUTIONS FOR EVERY APPLICATION



PH Cell MAX PALLET HANDLING

- + Up to 21 pallets
- + Ideal for DMU due to integrated twin pallet changer
- More on page 49



LPP – LINEAR PALLET POOL PALLET HANDLING

- + Up to 99 pallets on two levels
- + Interlinking of up to eight machines



PH- & TH-AGV PALLET & TOOL HANDLING

- + linking of several machines
- + Maximum scalability and free layout design



WH Flex WORKPIECE & PALLET HANDLING

- + Interlinking of several machines and technologies (turning, milling, etc)
- + Integration of secondary processes such as washing, deburring, etc.

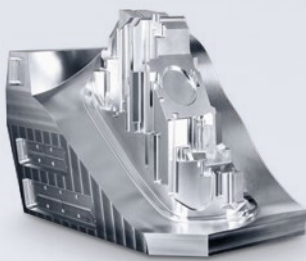

DIE & MOLD

- Swivel rotary table mounted on both sides for workpieces up to 1,000 kg
- + Direct Drive C-axis with 80 rpm

SEMICONDUCTOR

- Highly stable and low-vibration monoBLOCK design
- + Thermosymmetrical design, high repeatable accuracy to 6 µm



360°

Technology competence



E-MOBILITY / AUTOMOTIVE

- HSK-A 100 interface for tools up to ø80 mm
- + linear drives in X- & Z-axes up to 100 m/min

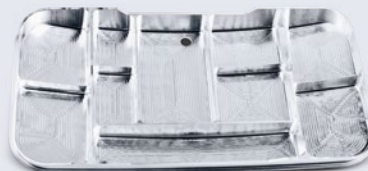

AEROSPACE

- Ideal chip evacuation due to horizontal 5-axis machining
- + speedMASTER spindles up to 30,000 rpm



ENGINEERING / JOB SHOP

- Simple and flexible automation solutions from a batch size of 1
- + wheel magazine up to 453 tools, 650 mm max. tool length



The 5-axis horizontal machining centers are not only productive, but they are also extremely precise and have low vibration. In conjunction with the efficient chip evacuation, they are ideal for automated and reliable production, 24/7.

Bernhard Lehr (left) and Andreas Müller
 Managing Director
 MS Powertrain Technologie GmbH

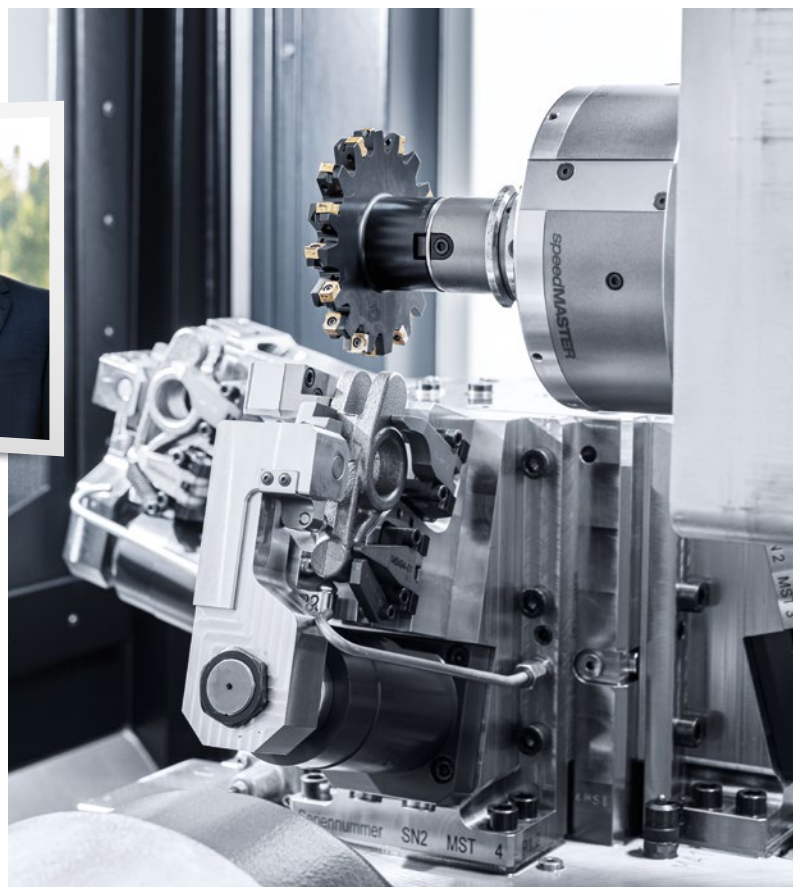

DMG MORI supplied the DMU 65 H monoBLOCK with special workholding from a single source.

MAXIMUM FLEXIBILITY IN MASS PRODUCTION

MS Powertrain Technologie GmbH has been a reliable manufacturer of precision components for vehicles, engines, transmissions and machinery since 1965. Customers from Germany, Europe, Brazil and the USA, including those from the off-road and commercial vehicle industries, put their trust in the quality components. About 350 skilled staff currently ensure efficient production of small and large batches in a plant in Trossingen-Schura, which was opened in 2016. The new facility also has plenty of space for shop floor modernization, as demonstrated by the acquisition of a total of 24 DMU 65 H monoBLOCKs from DMG MORI, which machine rocker arms for engines fully automatically to high precision and cost-effectively, around the clock.

Holistic customer focus

MS Powertrain regards itself as an all-round partner to its clients. "We support our customers with our know-how during the development phase if required," explains Bernhard Lehr, who manages the company together

with Andreas Müller. He points out the high degree of vertical integration: "Since we combine almost every stage of production under one roof, we can react with considerable flexibility at any time." In addition to milling, the company's manufacturing skills include deep hole drilling, thermal deburring, grinding and hardening.

AUTOMATED SERIES PRODUCTION ON 24 DMU 65 H monoBLOCKs

5-axis simultaneous machining for prototyping and small batch production

The investment in DMG MORI machine tools took place in 2014. At that time, MS Powertrain shared a location in Spaichingen with its sister company MS Ultraschall

Technologie GmbH. "Numerous machining centers and lathes from DMG MORI were already installed there, meaning that we knew about their reliability and performance," reminisces Bernhard Lehr. The company purchased the first of its own machines specifically for producing prototypes and small batches. These included a DMU 95 monoBLOCK and a DMU 80 eVo for 5-axis simultaneous machining.

DMG MORI: Wide range of products and future-oriented technology

After good experience with the initial machines and with a view to winning a major new order from the commercial vehicle industry, MS Powertrain invested in machine tools from the technology leader again in 2020. "Due to the wide range of products and the focus on future topics such as digitization, DMG MORI can put together bespoke and, above all, innovative manufacturing solutions," says Andreas Müller.

24 DMU 65 H monoBLOCK: Efficient, high precision machining of rocker arms

The large volume of the new order and the numerous component variants required versatile machining centers. MS Powertrain found what it was looking for in the DMU 65 H monoBLOCK. A total of 24 models will be installed by 2022. Thomas Greber, Head of Technology Development and Pascal Benz, Head of Production at the company, are more than satisfied: "The 5-axis horizontal machining centers operate with extreme precision and low vibration." The accuracy of the DMU 65 H monoBLOCK results from

the high-stability monoBLOCK design, the clamping of the swiveling rotary table and the thermo-symmetrical design. "Travels of 650×950×700 mm are also ideal for a wide range of components," says Pascal Benz.

Reliable production thanks to the H-monoBLOCK concept

Efficient evacuation of chips during horizontal machining contributes to very reliable production – which is important for MS Powertrain as all 24 of the DMU 65 H monoBLOCK machines are automated. A robot picks up the raw material, aligns it

and loads the machine. "There are individual workholding arrangements for the rocker arms, which DMG MORI supplied from a single source for the initial machines from its own fixture manufacturer," adds Thomas Greber. After the machine has been unloaded, the parts are automatically finished so that they arrive at the logistics department ready for delivery.

Growth through flexible automation

Whereas large orders such as this latest one indicate very positive business development, Bernhard Lehr still expects increasing diversification of the market and therefore increasing numbers of smaller batch sizes: "We therefore have to continue becoming increasingly flexible in order to meet the requirements of our customers and remain competitive." Automated production on the DMU 65 H monoBLOCKs has created a perfect platform for this. The strategy will continue to play a role at MS Powertrain in the future, as Andreas Müller adds: "Another plant is currently being built in Detroit with which we want to sustainably strengthen our position in the USA."

MS Powertrain manufactures large batches of rocker arms in different versions using a total of 24 DMU 65 H monoBLOCK machines.

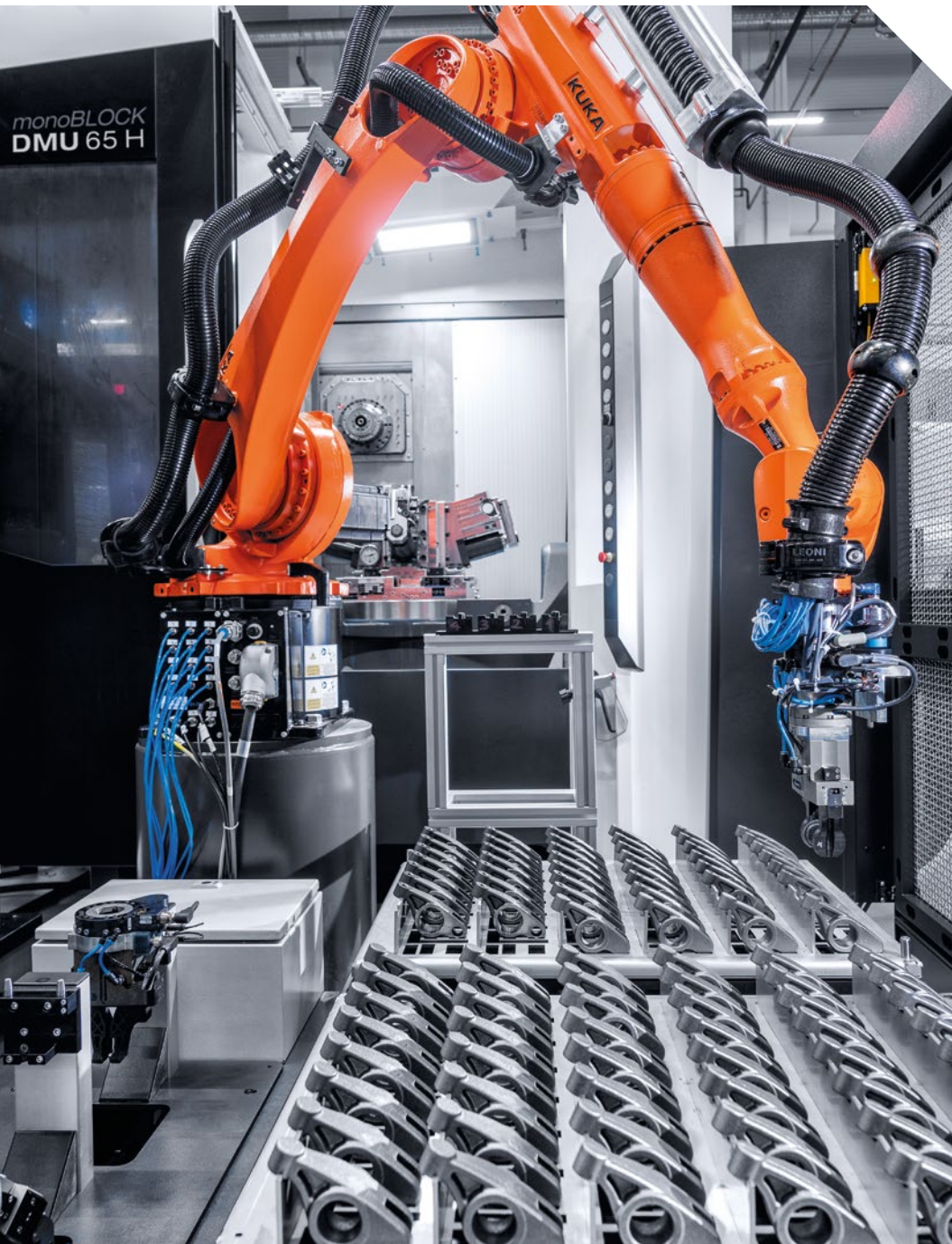

«

MS POWERTRAIN TECHNOLOGIE FACTS

- + Established in 1965
- + About 350 specialists at the company headquarters in Trossingen-Schura
- + Manufacture of engine components for the off-road and commercial vehicle sectors, among others



MS Powertrain Technologie GmbH
 Neuenbühlstraße 6
 D-78647 Trossingen-Schura
 Germany
www.ms-industrie.de



AUTOMATION PORTFOLIO WITH 13 PRODUCT LINES AND 57 PRODUCTS

CHANGEOVER TIME



WORKPIECE HANDLING

PALLET HANDLING

TURNING



IMTR (NTX 1000)



SR (WASINO)



NEW

Robo2Go

Robo2Go MAX



NEW

MATRIS Light

MILLING



WH Cell 1

Robo2Go Milling



Robo2Go Milling



AWC (NMV/CMX V)



PH Wheel³



RPS²

NEW

PH Cell MAX / PH Cell



PH Cell MAX / PH Cell



PH 150



PH 50

NEW

SPECIFIC TO THE MACHINE

UNIVERSAL (1 MACHINE)

THE DRIVERLESS
TRANSPORT SYSTEM

AGV – AUTOMATED
GUIDED VEHICLES



*DMG MORI always thinks
one step ahead – collaborative
and autonomous workpiece,
pallet and tool handling with
our AGV solutions.*

Harry Junger
Managing Director of
GILDEMEISTER Drehmaschinen GmbH



MATRIS

GX/GX T

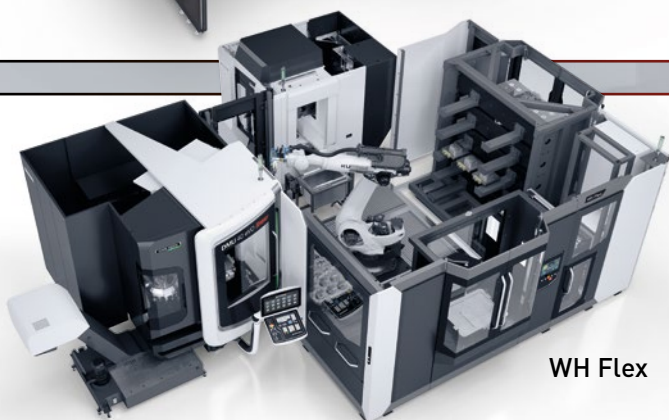

WH Flex



WH-AGV



LPP

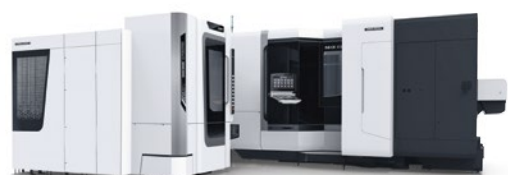

CPP

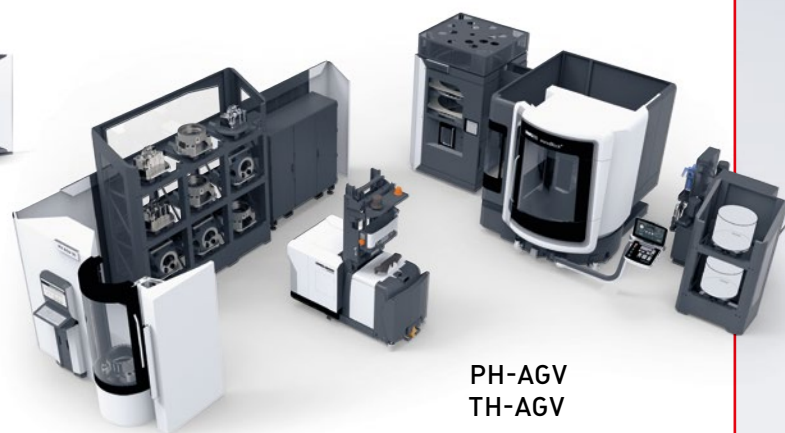

PH-AGV
TH-AGV

SCALABLE (≥ 1 MACHINE)

→ COMPLEXITY

¹ DMP, CMX V, CMX U, DMU, DMU monoBLOCK, DMU eVo, LASERTEC

² NHX, DMC H *linear*, monoBLOCK, duoBLOCK, portal

³ DMC 65 monoBLOCK, DMU 65 H monoBLOCK

RETROFIT AUTOMATION NOW AND BENEFIT

UNLOCK 24/7 OPERATION
OF YOUR EXISTING MACHINES
WITH RETROFITTED AUTOMATION!



YOUR ADVANTAGES:

- + Compensates for shortage of skilled personnel
- + One operator for several machines at the same time
- + Unmanned shifts, high autonomy
- + Short payback times, maximum added value
- + Reduced set-up times

OUR PROMISE:

- + Professional site management
- + One contact for everything
- + CE certification



RETROFIT AUTOMATION

DMU 75 monoBLOCK + PH Cell



WITHOUT AUTOMATION

DMU 75 monoBLOCK
Stand alone, 1-shift operation
75% spindle hours = 1,560 h/year*

*52 weeks × 5 days × 8 h = 2,080 h/a **52 weeks × 7 days × 24 h = 8,736 h/a

Torsten Zwerenz
Head of Global Service Systems
torsten.zwerenz@dmgmori.com
Tel. +49 (0)83 63 89 29 17



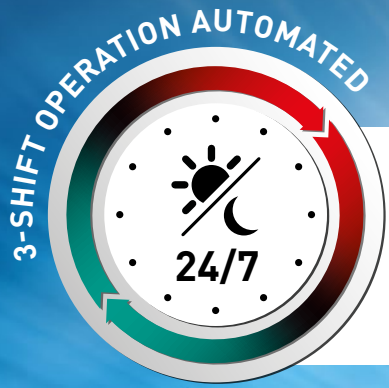

WITH AUTOMATION

DMU 75 monoBLOCK + PH Cell
Automated 24/7 shift operation
75 % spindle hours = 6,552 h/year**

AMORTISATION
< 6 MONTHS
(AUTOMATION)



RETROFITS FOR YOUR EXISTING MACHINES

TURNING MACHINES

- + MATRIS (Light)
- + Robo2Go (MAX)
- + WH 6/8/15/25 Cell
- + WH Flex

MILLING MACHINES

- + PH Cell (MAX)
- + PH 150
- + CPP // LPP
- + MATRIS (Light)
- + Robo2Go Milling
- + WH 3/6/8/15/25 Cell
- + WH Flex

AUTOMATION-CHECK:

Which machine can be retrofitted with which automation solution?

Our experts will be happy to advise you!

automation-retrofits@dmgmori.com

GROWTH THROUGH AUTOMATION

MODERNIZATION INSTEAD OF EXPANSION



Having to reliably produce over 4,000 parts per week around the clock was one thing, but we had hardly any space. The DMP 70 with WH 3 Cell, which was specially adapted for us, was exactly the right solution as its footprint is less than 9 m².

Florian Grießhaber
Managing Director
CNC Grießhaber

For almost 30 years, CNC Grießhaber has proven to be a reliable manufacturing service provider for customers in the automotive, mechanical engineering and medical industries. One key focus of the three-member team is high-precision machining of components from aluminum pressure die and sand castings. To remain competitive in the long term in spite of the limited production space in the former garage, CNC Grießhaber regularly invests in the modernization of their machinery – since 2018 in machine tools from DMG MORI. After the purchase of a CMX 70 U for 5-axis machining, a 4-axis DMP 70 with WH 3 CELL was added in 2021 and marked the start of around-the-clock automated manufacturing.

Sand and pressure die cast aluminum workpieces from a batch size of 50

The daily challenge for CNC Grießhaber lies in winning orders that on one hand fill their production capacity and on the other are a right fit for their niche. “Over time, we have tended to specialize in machining aluminum pressure die castings and sand castings,” explains Florian Grießhaber, grandson of the company founder and managing director since 2014. Workpieces made of cast aluminum are often quite unstable, making them difficult to machine. Another strength of CNC Grießhaber is the wide range of batch sizes. “We cover everything from small batch runs of 50 parts up to large series production involving 250,000 parts per year,” says Florian Grießhaber.

DMP 70 with WH 3 Cell: Compact automation for economical series production

One such large order involved manufacturing headlight components out of aluminum pressure die castings. It was a Europe-wide tender that CNC Grießhaber was able to win. “We needed a manufacturing solution to enable us

to deliver 4,000 parts per week economically,” Florian Grießhaber remembers. “There was practically no way we could do this without an automated system.” As it was not possible to expand the production space, the automated machine needed to be as compact as possible. In this case, the DMP 70 with WH 3 Cell with a footprint of just 8.8 m² was the optimal solution.

TURNKEY SOLUTION FOR 3-SHIFT OPERATION

DMG MORI tailored the manufacturing solution to the requirements of CNC Grießhaber and delivered everything from a single source. The result is a customized solution, as Florian Grießhaber explains: “The robot has a triple gripper so that we can clamp four parts at the same time. An alignment station precisely positions the part and special workholding has been installed in the machine.” The capacity of the parts storage in the WH 3 Cell was also maximized. “This means we can leave the machine to run unattended for up to 15 hours.” It also means that 3-shift operation is possible with practically no additional staff.

Short cycle times with 2g acceleration and 1.5 seconds tool change

The DMP 70 is an extremely powerful, compact machining center in DMG MORI’s product range. The inline spindle is rated at 10,000 rpm and 78 Nm torque; 24,000 rpm and 52 Nm are optionally available. DMG MORI also offers a 5-axis version with swiveling rotary table in its product range. With the high volumes that CNC Grießhaber produces on

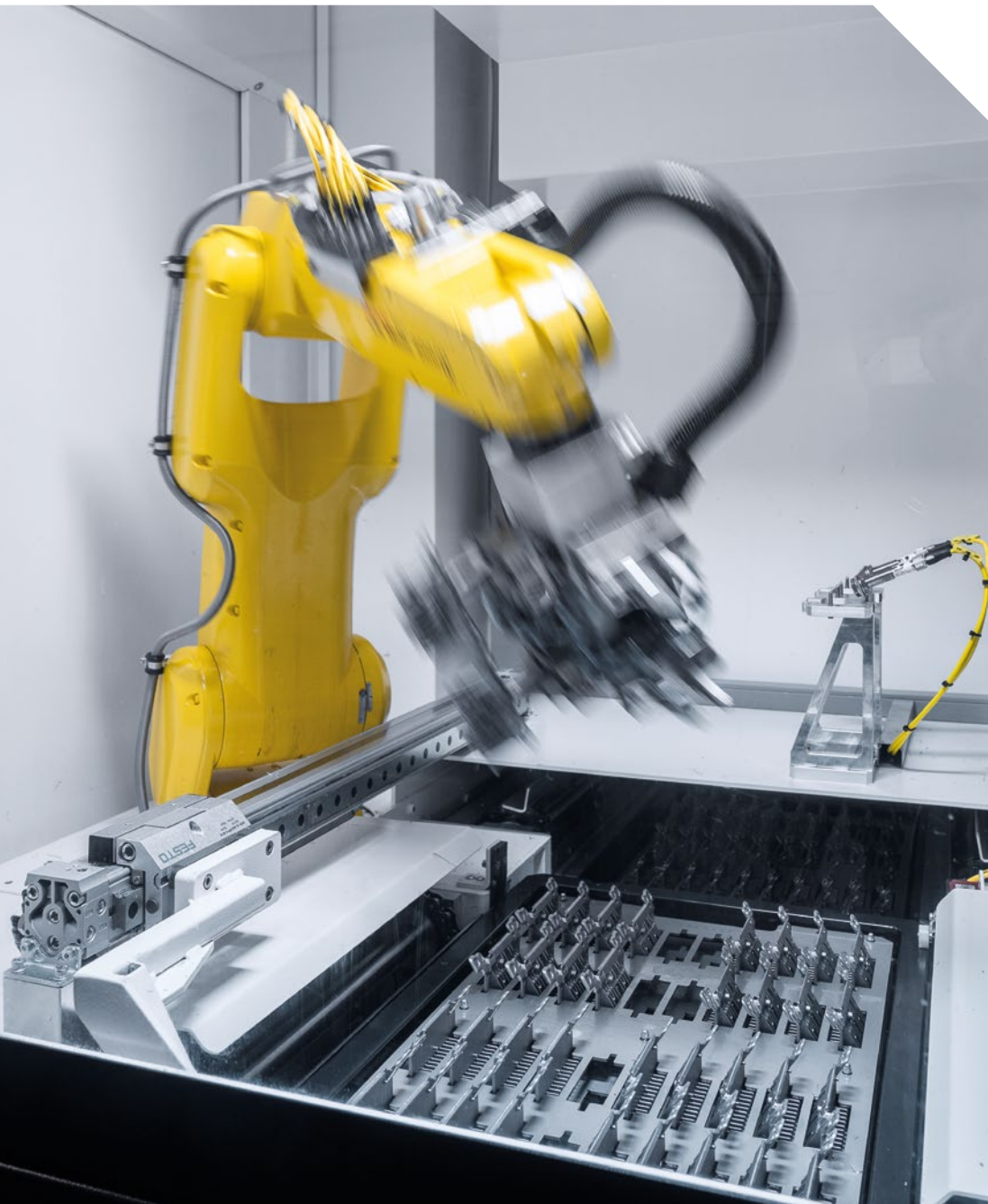

The WH 3 workpiece storage serving the DMP 70 offers space for up to 600 parts, enabling unattended production for up to 15 h.

the DMP 70, the short chip-to-chip time of 1.5 seconds at an acceleration of 2g have a noticeable impact, as does the 60 m/min rapid traverse in X, Y and Z.

DMG MORI: Convincingly reliable

Following its positive experience with the 5-axis CMX 70 U, which has been in use since 2018, CNC Griesshaber purchased the automated DMP 70. "Both machines always work reliably," Florian Griesshaber is pleased to report. If he needs support, he makes use of the fast service provided by *my*DMG MORI, the free customer portal. Faults are communicated online and forwarded directly to the right service experts. This ensures an efficient and transparent service.

The future lies in automated production

After the first few months using the WH 3 Cell, Florian Griesshaber is aware that the future of his company lies in automated production: "The investment has shown us that we can remain competitive by modernizing and making our existing machinery more productive." He is already thinking about the next step: "We would also like to automate 5-axis machining with our next purchase."

«



Griesshaber manufactures over 4,000 headlight components per week in 3-shift operation in a footprint of less than 9 m².



The workholding was specially designed for the process and has space for four workpieces.

CNC GRIESSHABER FACTS

- + Founded in Königsfeld in 1993
- + Team of three
- + High-precision machining of components from aluminum pressure die and sand castings
- + Customers in the automotive, mechanical engineering and medical industries

CNC Griesshaber

CNC Griesshaber
Fallenweg 12
78126 Königsfeld, Germany
www.cnc-griesshaber.de



Robo2Go – STANDARD AUTOMATION BUT FLEXIBLE TO SUIT YOUR WORKPIECES

THE Robo2Go APP: ONE FOR EVERYONE!
TURNING, VISION, MILLING

- 1. Integrated app for uniform control** – no adaptation of the existing NC programs.
- 2. No robot programming knowledge required**
- 3. Process creation based on predefined program modules**
- 4. Setting up a new workpiece <5 minutes**
- 5. Multijob function:** different jobs on one workpiece tray, **ideal for small and medium batch sizes.**
- 6. Home function** for simple retraction and system setup



AVAILABLE FOR 34 DMG MORI MACHINES

E. G.: CLX, CLX TC, CTX, CTX TC, NLX, NZX, NTX, DMU, DMC V



Robo2Go MILLING

- + Handling of workpieces up to 200×200×200 mm as standard. Other dimensions on request
- + Now with alignment and turning station. For automated 6-sided complete machining
- + Full accessibility to the machine thanks to loading from the side



Robo2Go TURNING

- + Handling of shafts $\varnothing 20 - 170$ mm and chuck parts $\varnothing 20 - 175$ mm
- + Laser scanner with automatic restart
- + Now with alignment and turning station.
- + Enables the gripping of long shaft workpieces



NEW MODULES FOR MORE WORKPIECE WEIGHTS

- + Cost-neutral migration of the new robot modules
- + 25 kg module also available for the Robo2Go MILLING

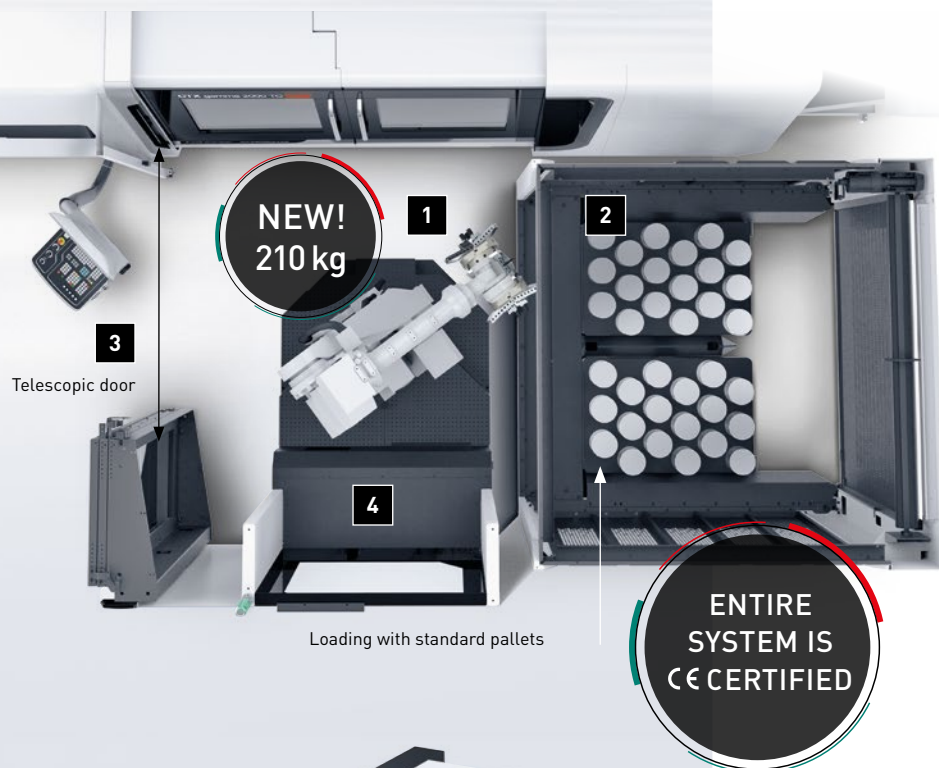

1. Basic module

Robot, control cabinet, cover

2. Storage module

Basic variant for two EU pallets with roller shutter:

- Rotate the module by ± 90 degrees to change the loading direction
- AGV-capable

3. Flexible tower and safety system

- Telescopic door for good access to the machine and automation
- Left- and right-sided installation variant possible

4. Extensions

Space for upcoming options such as: Alignment station, turning station

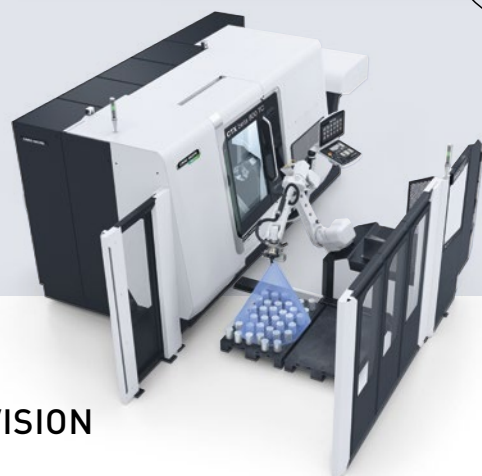

Robo2Go VISION

- + Robust 3D camera detection, ideal for multi-job function
- + Simple and fast set-up of new workpieces by means of a camera
- + Now with alignment and turning station. For accurate orientation of the workpiece in the fixture



Robo2Go MAX

- + Strongest version with 210 kg payload and 115 kg workpiece weight
- + Handling of workpieces $\varnothing 40$ to $\varnothing 400$ mm as standard
- + Free accessibility to the control system and the tool magazine



PRODUCTIVITY PLUS

THANKS TO THE B-AXIS
AND Robo2Go

Image left: **Unmanned night and weekend shifts** – Heppler produces complex hydraulic components, such as this stainless steel housing, on the new CLX 450 TC with Robo2Go.

Founded in 1984, Heppler GmbH from Spaichingen has made a name for itself as an expert contract manufacturer in numerous industries. Together with Heppler Montage-Technik GmbH and Kuder GmbH CNC Technik in Herrenberg, which are also a part of the group of companies, a total of 340 employees concentrate on the production of products for the electronics industry, mechanical engineering, the hydraulics sector and the medical industry, among others. Heppler has been using machine tools from DMG MORI for its manufacturing since 2018 – first for training and soon also for daily business. The fleet of machines now includes ten machining centers and turning machines. Recently a CLX 450 TC with Robo2Go was installed – the first example of a new turn-mill center delivered by DMG MORI. Along with five NHX 5000s including an RPS 14 rotary pallet storage system, Heppler uses other automation solutions.

GROWTH THROUGH MODERNIZATION AND AUTOMATION

“Our positive growth is partly the result of having concentrated on future-oriented industries,” says Dieter Heppler, managing director of Heppler GmbH. “As a service supplier to these industries, we will only retain our competitive edge if we can continue to develop our expertise and optimize processes in a sustainable way.” Heppler therefore regularly invests in education and further training, as well as the modernization of its machinery. Modernization measures include replacing older machines, increasing capacity and automation of production.

CLX 450 TC:

From plastic to stainless steel, precision to within tens of microns for all batch sizes

Contract manufacturing often includes the most diverse requirements as part of day-to-day work. Dieter Heppler can attest to this: “We frequently change over production of components that are sometimes highly complex and have to machine them to high precision, within tens of microns, from different materials from plastic and copper through to aluminum and stainless steel.” This is the reason why his team relies on advanced manufacturing solutions. “Only in this way are we able to produce our range of components economically.” The latest example of one such manufacturing solution is a CLX 450 TC, which Heppler recently added to its fleet of machines. It is the first model of the new turn-mill center that DMG MORI has installed at a customer’s site.

CLX 450 TC WITH Robo2Go

6-SIDED COMPLETE MACHINING WITH B-AXIS 100% TURNING

100% TURNING

- + Integrated spindle drives up to 5,000 rpm and 345 Nm as well as C-axis (0.001°)
- + 6-sided complete machining at the main and optional counter spindle
- + Workpieces up to $\varnothing 400 \times 1,100$ mm in a footprint of 7.1 m²

100% MILLING

- + compactMASTER turning/milling spindle with 12,000 rpm and 90 Nm

100% MORE TOOLS

- + Tool magazine with up to 60 pockets, 30 pockets as standard

Robo2Go

- + Flexible automation solution for unmanned shifts



NHX 5000 WITH RPS 14

FLEXIBLE PALLET AUTOMATION UP TO 700 kg

- + Handling of workpieces up to $\varnothing 800 \times 1,000$ mm, 700 kg
- + Prepared for unmanned production with various options
- + 14 pallet positions (500 x 500 mm) on two levels with one set-up station
- + Easy operation via machine control with intuitive and integrated Pallet Manager software



Heppler uses 3 NHX 5000s for automated manufacturing of hydraulic components made of stainless steel, which are all automated with an RPS 14-station rotary pallet storage system.

Automated entry to 6-sided complete machining thanks to the B-axis and Robo2Go

With the CLX 450 TC, DMG MORI has developed a turn-mill center that offers its users affordable entry into 6-sided complete machining. "This favorably-priced machine concept was a convincing reason for the acquisition," reflects Dieter Heppler. Since then, the CLX 450 TC has been responsible in particular for complex workpieces made of aluminum and stainless steel. "We also installed a Robo2Go from DMG MORI so that we could use the machine for unmanned third shifts overnight and at the weekend," explains Dieter Heppler. In particular, smaller batch sizes can be processed completely autonomously in this way. For larger series, work is limited to simply loading the Robo2Go.

Heppler also found an efficient manufacturing solution from DMG MORI's product range for producing its wide range of hydraulic valve manifolds from stainless steel. The

team produces components in small and medium-sized batch on three NHX 5000 horizontal machining centers with RPS 14. "The setup of towers in parallel with production provides a real boost to productiv-

NHX 5000 AND RPS 14: 14 PALLETS WITH TOWER LOADING

ity," says Dieter Heppler. With 14 positions for 500 x 500 mm pallets on two levels, it is possible to load numerous orders while the powerful machine continues to mill. Up to 60 m/min rapid traverse and 1.2g acceleration speaks for itself. The compact design was another reason in favor of the automation solution with RPS 14: "The ratio of capacity to footprint is perfect for us."

Flexible automation solutions for the future

Heppler will continue to practice its modernization philosophy when making future investments. "Growth of up to 15 percent in recent years has confirmed our decisions," sums up Dieter Heppler. That is also why future purchases will be made with the same considerations in mind: "Innovative manufacturing technology and flexible automation solutions play a central role in this." A fourth NHX 5000, also with RPS 14, will be installed early in 2022.

«



We have been able to achieve growth of up to 15% in recent years through innovative manufacturing technologies and flexible automation solutions, such as the CLX 450 TC with Robo2Go, or the NHX 4000 with 14-station rotary pallet storage.

Dieter Heppler, managing director
together with **Astrit and Patrick Heppler**
Heppler GmbH

HEPPLER FACTS

- + Founded in Spaichingen in 1984
- + 340 employees
- + Manufacturing service provider for innovative products for the electrical industry, mechanical engineering, medical sector and hydraulics industry, amongst others



Heppler GmbH
Wilhelm-Maybach-Weg 5
78549 Spaichingen, Germany
www.heppler.de



HAIMER –

Your system partner around the machine tool

HAIMER.
Quality wins.



Tooling Technology

Shrinking Technology

Balancing Technology

Measuring- and Presetting Technology

www.haimer.com

MATRIS Light

HIGHLY FLEXIBLE &
COLLABORATIVE AUTOMATION
FOR WORKPIECES UP TO 5 kg

HIGHLIGHTS

- + **Freely movable workpiece handling, incl. robot and storage area on a trolley**
 - Workpieces up to 5 kg, or 2×2 kg with double gripper
 - No infrastructure changes
 - No safety fence necessary
 - 600×900 mm footprint
- + **Collaborative robots, setup time <5 minutes**
 - Direct teaching without robot knowledge
 - Easy connection via Ethernet
- + **Expansion (option)**
 - Storage for up to 108 workpieces (2-position storage for max. 36 as standard)
 - Blow-off device
 - Measuring system and quality check
 - etc.
- + **Available for 20 machines**
 - **TURNING:**
NLX 1500, 2000, 2500/ALX 1500, 2000, 2500/
NTX 1000, 2000, 2500/NZX 1500, 2000, 2500
 - **MILLING:**
CMX 600, 800, 1100 V/i 30 V/NHX 4000/
CMX 50 U/DMU 50/DMU 40 eVo



INSTALLATION IN < 5 MINUTES



All in one – Easy to move trolley

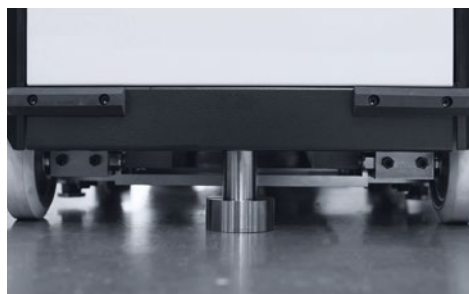

Secured via 3-point support



Plug & Play Ethernet connection

MATRIS Light
+ workpiece storage
= space requirement
of one operator



EXPANSION OPTIONS



Measuring system
and quality check

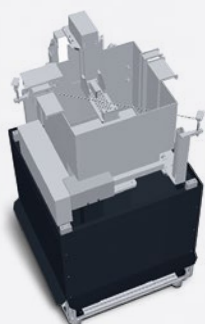

Blow-off device



2-position storage
as standard

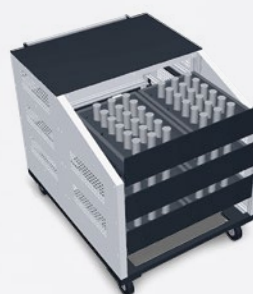

6-position storage

Options for storage
(2- /6-position):
18 × ø 50 mm or
12 × ø 100 mm or
6 × ø 150 mm



Easy operation via touchpad



Direct teaching by moving the robot



Position compensation with tags (option)

PH Cell

MODULAR PALLET HANDLING
FOR UP TO 40 PALLETS

300 kg
TRANSFER
WEIGHT

Retrofittable!

Connection to existing machines
possible if automation
interface already integrated

PALLET CHANGE DEVICE
Up to 300 kg transfer weight
(workpiece incl. pallet)

HIGHLIGHTS

- + **Unrivalled ergonomics and accessibility** to the work area thanks to loading from the side
- + **Modular design** to suit individual customer requirements
- + **Subsequent expandability** with a second shelf module
- + **Simple adjustability** of shelf heights
- + **Separate setup station** for ergonomic preparation of pallets during production
- + **Short commissioning time** thanks to defined interface and modular principle
- + **Attractively priced** automation in the DMG MORI VERTICO design

Available for:

- DMU 65/75/85/95 monoBLOCK
- DMU 65 H monoBLOCK
- DMU 50 3rd Generation
- DMU 40/60/80 eVo
- DMU 80/90 P duoBLOCK
- CMX 50/70 U
- CMX 600/800/1100 V

SEPARATE SETUP STATION
+ Ergonomic setting-up
+ Rotatable option

PHCell

NEW: PH CELL MAX

NEW! PH Cell MAX

PALLET STORAGE
UP TO 21 PALLETS
ø 1,100 mm AND 2,000 kg

2,000 kg
TRANSFER
WEIGHT



Versatile!

Rack modules can be combined for different pallet sizes



| pallet size | workpiece height | |
|--------------|------------------------|--------|
| | 500 mm* | 300 mm |
| | max. number of pallets | |
| 500 x 500 mm | 18 | 24 |
| 400 x 400 mm | 24 | 32 |
| 320 x 320 mm | 30 | 40 |

*top shelf no restriction on component height

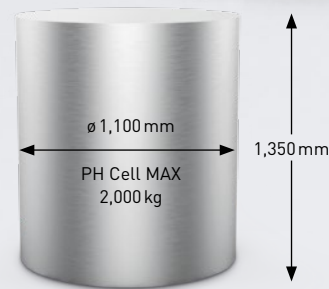

Available for:

- DMU 65 H monoBLOCK
- DMU 85 H monoBLOCK
- DMU 80 P/FD duoBLOCK
- DMU 90 P duoBLOCK
- DMU 100 P/FD duoBLOCK
- DMU 125 P/FD duoBLOCK

| pallet size | workpiece height | | |
|----------------------------|------------------------|--------|--------|
| | 1,350 mm | 750 mm | 350 mm |
| | max. number of pallets | | |
| 500 x 500 mm to ø 1,100 mm | 12 | 17 | 21 |

»

PH Cell MAX

MODULAR ROTARY PALLET STORAGE
FOR UP TO 21 PALLETS



Retrofittable!

Connection to existing machines possible if automation interface already integrated



Compact!

up to 21 pallets in a 16.5m² footprint

CONSTRUCTION KIT

Modular concept for individual customer requirements with 2 different sizes and 2, 3 or 4 shelf levels

handling device



- + Fast pallet change in under 45 seconds due to double gripper fork
- + Handling device for pallets from 500 x 500 mm to ø1,100 mm

shelf storage



- + Heavy loads possible with 2,000 kg per storage location
- + Fast commissioning. The shelf storage system is transported as a whole including the handling device
- + Maximum 21 pallets on 4 levels in the overall system

setup station



- + Rotatable setup station as standard
- + High precision FD setup station optionally available
- + Setup station optionally available in conjunction with clamping hydraulics

NEW:
palletMASTER
Software

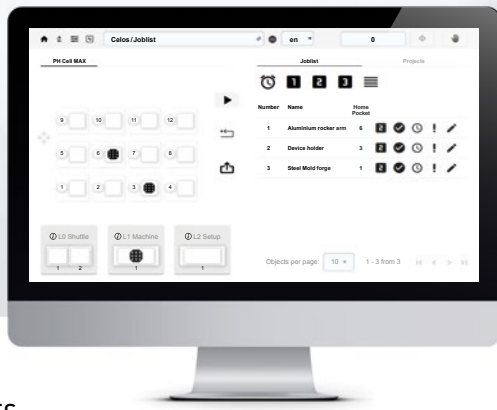

HIGHLIGHTS

- + Transfer weight up to 2,000 kg
- + 12 to 21 pallets in system, pallet size 500 x 500 mm to ø1,100 mm
- + Fast pallet change time < 45 seconds
- + Can be retrofitted with machine preparation
- + Short commissioning time within 3 days due to defined interface and modular principle

The fast double gripper fork with changeover times of less than 45 seconds loads directly into the work area – this means that the rotary pallet changer can be omitted from the machine.

Andreas Lang
Head of Product Management
DECKEL MAHO Pfronten GmbH



**PH Cell MAX VS. RPS
IN DIRECT COMPARISON**

PH Cell MAX

- + **Retrofittable** for machines with automation interface
- + Also available for **DMU machines**
- + Up to **21 pallets** can be handled and stored in the system
- + Modular design with different pallet sizes
- + Integrated pallet changer in the handling device

RPS

- + **Machine-integrated solution** for DMC machines with pallet changer
- + **Maximum number of workpieces** corresponds to the machine
- + **Very fast pallet change times** due to the machine pallet changer
- + Also for **DMC 160 U/FD and Portal machines**



AREA COMPARISON

- + 16.5m² footprint of the PH Cell MAX with up to 21 pallets on 4 levels
- + 25% reduction in footprint compared to the RPS with 12 pallets

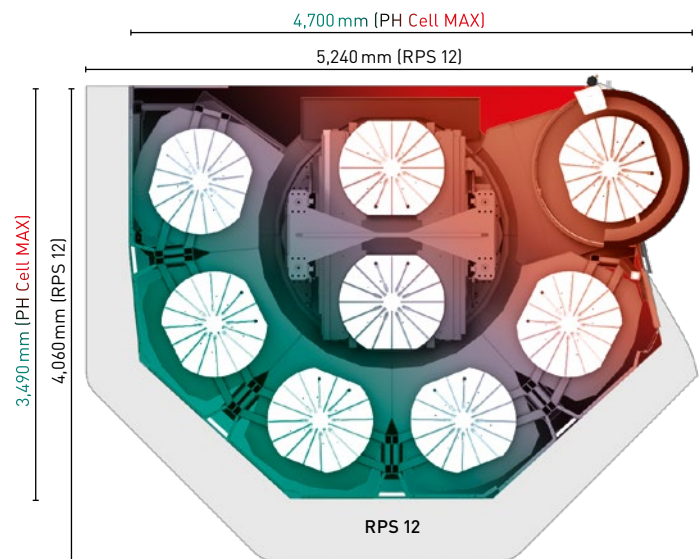

| | |
|---|--|
|  PH Cell MAX |  RPS 12 |
| 16.5 m ² | 21.3 m ² |

AUTOMATION AS A QUALITY FACTOR



Mayer Präzision manufactures a wide range of jig and fixture components – from a single part to medium-sized batch runs.

Mayer Präzision GmbH has been regarded as a reliable manufacturing partner for jigs and fixtures for assembly work in the automotive industry for over 30 years. It is a subsidiary of ASD Maschinenbau GmbH since 2016 with a staff of 30 specialists who work at the company headquarters on design and machining. Mayer Präzision has been relying on CNC technology from DMG MORI for its production for several years, as its latest acquisitions show. For the manufacturing service provider, two CMX 600 Vs, one with robotic automation and a DMU 50 3rd Generation with PH CELL are the entry into automated and thus more productive manufacturing.

Complex jigs and fixtures within just a few weeks

“As a service provider, we get involved in new projects for jigs and fixtures at a very early stage,” Christoph Glier, managing director of Mayer Präzision, explains the day-to-day business. As soon as an automobile manufacturer produces a new model or even just a facelift to existing models, they need the corresponding jigs and fixtures for the assembly process. The experienced team at Mayer Präzision provides support with the required expertise and manufactures the corresponding components. “We can deliver in just a few weeks, depending on the complexity of the jigs and fixtures.”

Training and reliable manufacturing processes as a success factor

The fact that Mayer Präzision completes orders in such a solution-oriented and efficient manner is due, on one hand, to its experienced employees and well-trained junior staff. “We try to employ two apprentices per year to cover our need for specialist staff,” says Christoph Glier. On the other hand, the modern machines contribute to productivity – and to the quality of the jigs and fixtures. Ferdinand Urlbauer, plant manager at Mayer Präzision, adds: “Modern and flexible machine tools allow us to produce our wide range of parts and to always guarantee the often high precision requirements.” DMG MORI has made a decisive contribution to this with stable machine tools and automation solutions that ensure reliable processing.

DMU 50 INCLUDING
PH CELL WITH
40 PALLETES IN
A FOOTPRINT LESS
THAN 26 m²

Mayer Präzision installed one such automation solution at the start of 2021 in the form of a DMU 50 3rd Generation and a PH Cell. “The combination unites machining flexibility and efficiency in one very compact footprint,” says Christoph Glier. This not only allows them to produce a very wide spectrum of components but also to fully utilize the capacity of the machine. The PH Cell has a modular



At the beginning of 2021, Mayer Präzision invested in a DMU 50 3rd Generation and two CMX 600 Vs.



Thanks to the automated DMU 50 and CMX 600 V, well trained specialists are free to concentrate on qualitative tasks such as programming and quality assurance.

Christoph Glier, managing director (left) and **Ferdinand Urlbauer**, plant manager (right) at Mayer Präzision GmbH

MAYER PRÄZISION FACTS

- + Founded in 1983
- + 30 skilled workers at its head-quarters in Hengersberg
- + Manufacturing of jigs and fixtures for assembly work in automotive engineering



Mayer Präzision GmbH
 Donaustraße 24
 D-94491 Hengersberg, Germany
www.mayer-praezision.de



design: the number of pallet positions for the maximum of two rack modules depends on the pallet size. 320×320 mm, 400×400 mm and 500×500mm being available. Mayer Präzision decided on smaller pallets and thus has a total of 40 storage positions. "The perfect capacity for our medium-sized batch runs," adds Ferdinand Urlbauer. The 5-axis-machining center is loaded from the side, which offers optimal accessibility to both the machine and the automated setup station. The PH Cell can be controlled via a user-friendly touch panel.

40 pallets for unmanned night shifts and increased quality

Mayer Präzision works two day shifts and uses the DMU 50 3rd Generation with PH Cell for unmanned night shifts and during the weekend. "We can thus benefit from the option of preparing orders requiring a long running time during the day and then manufacturing them automatically," says Ferdinand Urlbauer. Christoph Glier sees automation in terms of quality: "Automated manufacturing provides our well-trained staff with the freedom to concentrate on qualitative tasks, such as NC programming or quality assurance."

TULIP – digitization for process optimization

The modernization of its production processes, with which Mayer Präzision has been ensuring their competitiveness for several years, will also require future investments in

modern manufacturing solutions. Ferdinand Urlbauer is aware of this: "This also means we need to always be on the lookout for new technology – whether it was 5-axis machining in the past or additive manufacturing in the future." This also includes preparing personnel for future challenges. Christoph Glier considers the digitization of processes to be an important development. They have already looked into the possibilities offered by the self-created TULIP apps: "We will be able to optimize our production flow in a sustainable way using apps like this and other digitization products."

The DMU 50 3rd Generation is loaded from the side, which offers optimal accessibility to the machine and automation. The PH Cell is equipped with a total of 40 pallet storage positions.

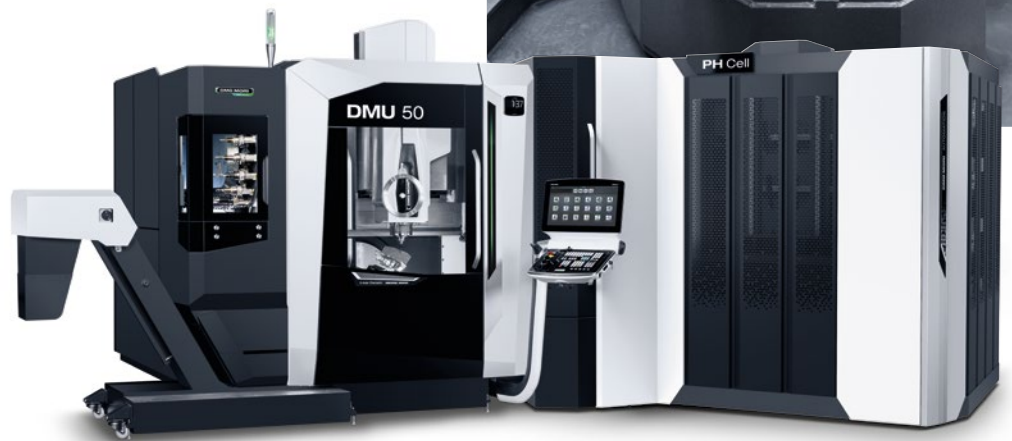

SUCCESS IN A NICHE AREA

INNOVATIVE ULTRASONIC MACHINING
FOR DEMANDING COMPONENTS
IN (EUV) LITHOGRAPHY SYSTEMS

HIGHLIGHTS ULTRASONIC 50

- + Perfect ULTRASONIC entry-level machine, available as 3-, 4-, 5-axis version with **15,000 rpm as standard.**
- + 4-axis version with **Direct Drive C-axis for up to 300 rpm** and cylindrical grinding cycle
- + **Full 5-axis simultaneous machining** with optional NC swivelling rotary table with -35° to 110° swivel range
- + ULTRASONIC microDRILL: **Adaptive attachment spindle for micro bores** from $> \varnothing 0.1$ mm at up to 32,000 rpm
- + ULTRASONIC 3rd generation for **maximum productivity and high process reliability**



UP TO
50 %
LOWER
PROCESS
FORCES

UP TO
3x
HIGHER
REMOVAL
RATES

RA
 $\leq 0.1 \mu\text{m}$
REDUCED
SSD

LASERTEC 50 PrecisionTool
with **PH 50** for the auto-
nomous series production
of diamond tipped tools up
to $\varnothing 355 \times 410$ mm.



HIGHLIGHTS

- + **Most cost-effective pallet automation** from DMG MORI
- + **Small footprint – only 2.7 m² (1.6 x 1.7 m)**
- + **Flexible use** for a wide range of DMG MORI machines
- + **Operation directly at the machine control**
- + **3x NC axes** for high flexibility and precision
- + **Various tool pallet configurations** for HSK-50, HSK-63, HSK-100, EROWA ITS 148, Schunk

AUTOMATION PH 50

THE MOST COMPACT AND COST-EFFECTIVE
PALLET AUTOMATION FROM DMG MORI



Wafer Chucks
Material: SiC



Rings
Material: Quartz glass



Shower Heads
Material: Al₂O₃



Mirror carrier
Material: Zerodur



Frame components
Material: SiC/Si₃N₄

PROCESS KNOW-HOW

Manufacturers in the semiconductor industry have long been aware of the advantages of ULTRASONIC-assisted grinding with ULTRASONIC machines:

- + Up to 50 % lower process forces during machining
- + Surface finishes of Ra $\leq 0.1 \mu\text{m}$
- + Up to 3-fold higher material removal rates.
- + Reduced scrap in production
- + Reduced sub-surface damage. minimized downstream polishing

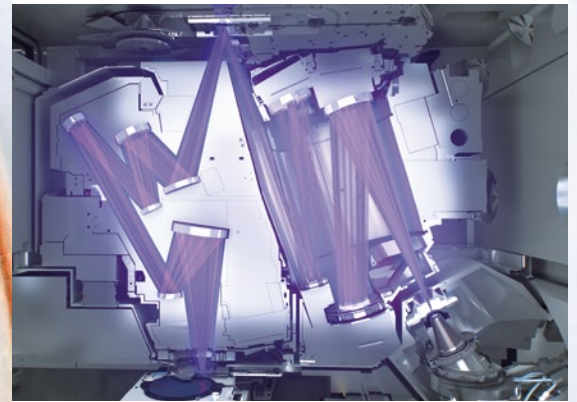

Source: ASML

With ULTRASONIC machines, quartz glass, Zerodur and technical ceramics such as aluminum oxide or silicon carbide are used to produce key components of extreme ultraviolet (EUV) lithography systems for microchip production!

CONFIGURATION EXAMPLES – TOOL PALLETS

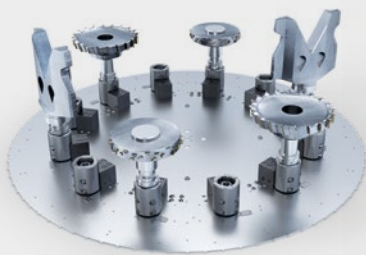

Up to 6 HSK63 tools
of max. $\varnothing 355 \times 410$ mm and
max. 30 kg weight



Up to 22 HSK63 tools
of max. $\varnothing 90 \times 410$ mm and
max. 30 kg weight

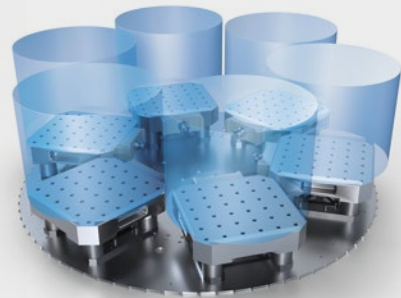

Up to 6 Schunk pallets
of max. $\varnothing 360 \times 405$ mm and
max. 70 kg weight

FLEXIBLE AND ENERGY-EFFICIENT PRODUCTION OF HIGH-PERFORMANCE TEXTILE MACHINES

Since 1888, the name Trützschler has stood for expertise in the preparation of textiles. The globally active group of companies founded Trützschler Textile Machinery (Shanghai) Co., Ltd. in China in 2001. At the site, around 500 employees produce and assemble blow rooms, carding machines and draw frames, among other things. There has been close cooperation with DMG MORI from the start, resulting in the installation of ten machine tools from the technology leader, including two NHX 8000s, one with a CPP linear storage system for seven pallets. The latest acquisitions were an NHX 6300 and an NHX 5500, each equipped with a rotary pallet storage system for 12 and 21 pallets respectively.

Increase in market share from 5 to 30%
Continuous growth of the textile industry is driving demand for high-performance, automated, intelligent textile machines. Trützschler knows the requirements of the local markets extremely well and aligns its development accordingly. The company is ensuring its own competitiveness and that of its customers by continuing to expand its range of products. Since 2001, Trützschler has been able to increase its market share from five to 30 percent in China, one of the largest textile markets worldwide. "In view of the continuous growth of Trützschler in the Chinese market and the positive outlook there, we need ever-increasing production capacity," explains Yi Wu, head of production at Trützschler in Shanghai.

Partnership and over 100 years of experience

Due to the small batch sizes and diverse variations, textile machines cannot be manufactured in standardized, large-scale production. That is precisely why Trützschler values flexible manufacturing processes. Harald Schoepp, managing director of Trützschler in China, considers DMG MORI to be the perfect partner: "Their experts have fulfilled all our expectations and reliably supported us in the optimization of our production processes." The cooperation benefits from over 100 years of experience and the similar business philosophies of both companies.



Trützschler uses an NHX with a 7-station carrier pallet pool (CPP) for automated manufacturing of large components.

The experts from DMG MORI fulfilled all our expectations and reliably supported us in the optimization of our production processes.

Harald Schoepp
 Managing Director
 Trützschler Textile Machinery (Shanghai) Co., Ltd.



DMG MORI fulfils the stringent requirements placed on flexibility and efficiency with its NHX models combined with a pallet storage system. "This allows us to machine a wide range of parts – automatically and in whatever order we need, depending on demand," says Yi Wu. The pallet priority can be set flexibly via the machine control system with

NHX WITH PALLET AUTOMATION FOR FLEXIBLE SMALL SERIES PRODUCTION

the integrated Pallet Manager software. "We can thus plan dynamically according to the customer order, production requirements and manufacturing technology." This allows us to maximize the utilization of our machining centers, despite the diverse, small batch production. "For Trützschler, this is a crucial factor in ensuring it is able to react quickly to customer demand and stay ahead of the competition."

Part of a carding machine



Simply implement machine status monitoring and global control

Digital applications from DMG MORI – Digital Monitoring, MESSENGER, Status Analyzer and PERFORMANCE MONITOR – support Trützschler in ensuring reliable manufacturing processes. MESSENGER presents users with the real-time status of a machine tool centrally on a mobile device, along with specific machine information including work status, current NC program and number of workpieces. The analysis and documentation of this information contribute to a reduction in the risk of downtime and an increase in productivity. In addition, it is possible to calculate the cost efficiency of the order based on the machine hours, downtime and error information. "We monitor and record operation in real time, while colored bars allow the status to be clearly visualized," says Yi Wu, explaining the functionality. Subsequent analyses enable machine utilization to be further improved.

NHX 8000 WITH CPP

- + Up to 29 pallet positions
- + Max. four machines with two setup stations
- + 800×800 mm max. pallet size, 2,200 kg max. load
- + ø1,450×1,450 mm max. workpiece dimensions
- + Control directly via the machine CNC or the DMG MORI MCC-LPS cell control system
- + MCC-TMS tool management system





Harald Schoepp, managing director of Trützschler in China and Zou Zhenhua, leader of the mechanical machining team, in front of one of the two NHX 8000s.

For him, it is important to look at MESSENGER every day and he prefers the status to be green: "That means the machines are running normally and as scheduled."

Condition monitoring thanks to an update to the latest CELOS version

There is no doubt that monitoring the status of the machine considerably improves the digitization process during production. However, the older machine tools do not have condition monitoring, which is why DMG MORI provided the required IoTconnector retrofit and the latest version of CELOS. This allowed Trützschler to network all DMG MORI machines that have been in use since 2017 – a big step towards digitization.

Sustainable development and innovation for a green future

The textile industry is also following the upswing of the green economy. As a leading



ENERGY-EFFICIENT AND LOW-EMISSION MACHINE

Up to 30% energy savings compared to previous machine models, e.g. through:

- + Energy recovery during braking
- + Demand-based control of process parameters and components
- + Energy saving app

UP TO 30% MORE ENERGY EFFICIENT COMPARED TO PREVIOUS MACHINE MODELS



company in the textile machine industry, Trützschler has always made a decisive contribution to the development trends within the industry, including in the areas of ecology and sustainability. Trützschler considers high energy efficiency and careful handling of raw materials to be important criteria in technological innovation and product development. In this way, the company helps its customers achieve sustainable, healthy growth.

Trützschler is committed to promoting sustainability in mechanical and plant engineering and offers sustainable solutions for industry. The company also practices these standards in its own production. Trützschler regularly removes old, energy-intensive machines and replaces them with high-precision, energy-saving automation solutions and digital products, for example energy-efficient and low-emission machines from DMG MORI. Moreover, DMG MORI is one of the first CO₂-neutral machine tool manufacturers in the world and therefore an ideal partner in this regard. When it comes to future cooperation between the two companies, Harald Schoepp looks forward to long-term collaboration: **“Trützschler and DMG MORI are both leaders in their individual fields and share a common development philosophy. We would like to promote sustainable development on this basis and move towards a CO₂-neutral future.”**

CO₂-NEUTRAL FUTURE – TWO COMPANIES, ONE PHILOSOPHY

TRÜTZSCHLER TEXTILE MACHINERY FACTS

- + Trützschler Group subsidiary founded in 2001 in Shanghai
- + 500 employees
- + Production of spinning machines and accessories, provision of localization services

TRÜTZSCHLER

Trützschler Textile Machinery Co., Ltd.
No.1033 Huijin Road, Qingpu
Shanghai, P.R. China, 201707
www.truetzschler.com



ENERGY SAVING APP REDUCES THE ENERGY CONSUMPTION OF YOUR DMG MORI MACHINE



- ✓ **Modern and simple energy management:**
 - + **Create transparency:**
Time- and NC block-related recording of machine performance and CO₂ emissions
 - + **Reduce energy consumption:**
Minimized energy consumption and increased productivity at the same time thanks to performance and consumption analyses, among other things
 - + **Save energy with auto shutdown:**
Shutdown, warm-up and standby function for the machine, pneumatic system, display and lighting
- ✓ **Free as standard**
for all machines with CELS V
- ✓ **Free retrofit**
also possible for older machines as update of any existing CELS version*

*a charge may be made for a SENTRON PAC3220 Power Monitoring Device

PUSHING THE CIRCULAR ECONOMY

TURNKEY SOLUTIONS FOR RECYCLING

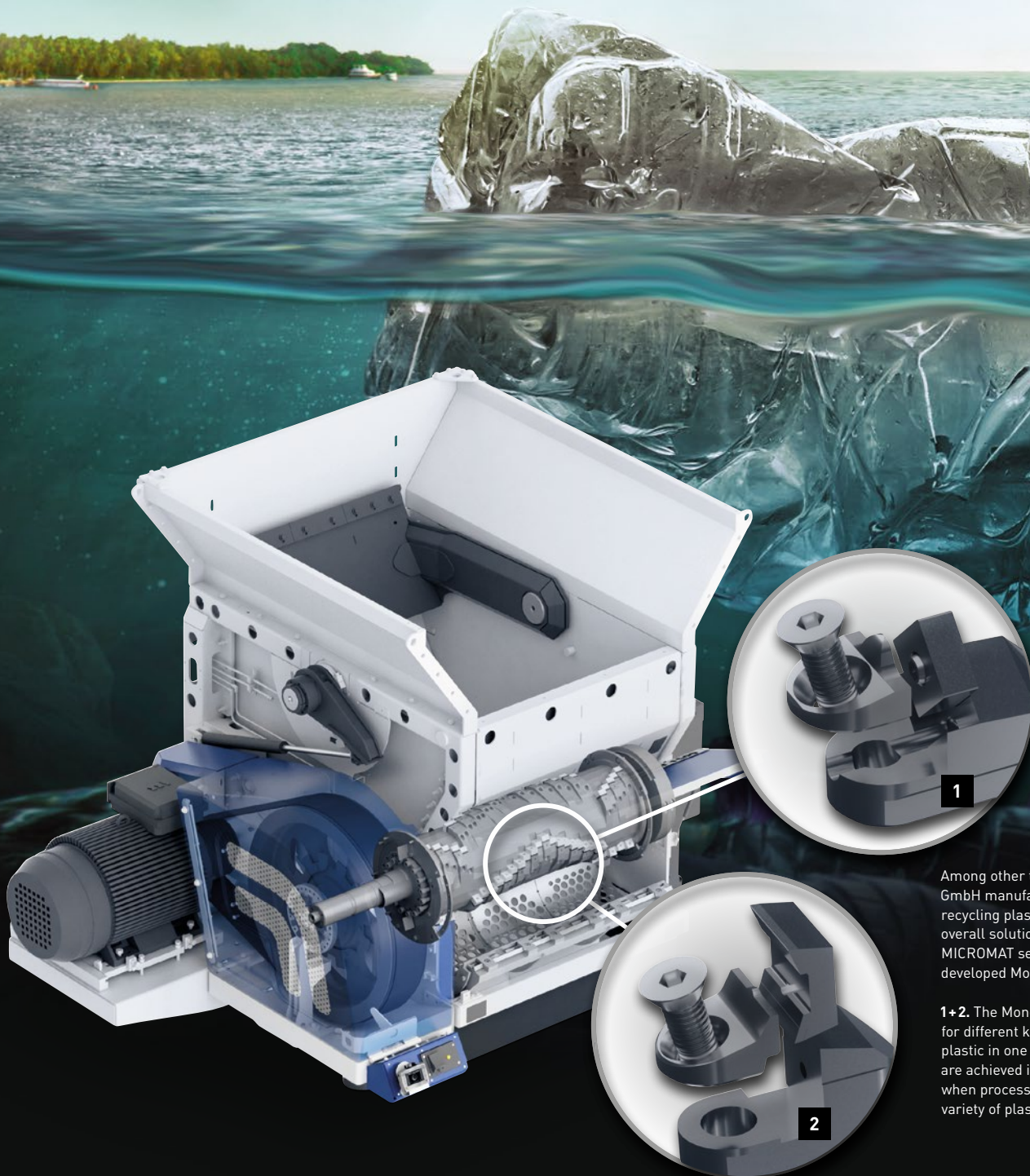

Among other things, Lindner-Recyclingtech GmbH manufactures integrated solutions for recycling plastics. An important part of the overall solution is the shredder, such as the MICROMAT series, in which the internally-developed Mono-Fix knife system is used.

1+2. The Mono-Fix system makes it possible for different knives to be used for shredding plastic in one machine. Optimal results are achieved in this way, particularly when processing a mixture of a wide variety of plastics.

TECHNOLOGY EXCELLENCE FOR GREEN TECHNOLOGIES

Such as recycling, wind power, hydroelectric power and electromobility – all important technologies for climate change mitigation



Lindner-Recyclingtech GmbH, a specialist in shredding and integrated solutions for waste processing, has been making a significant contribution to the circular economy since 1948. With more than 350 employees, Lindner develops and produces pioneering recycling solutions at 3 locations in Austria and thus sets standards for GREENTECH innovations. DMG MORI makes it possible for Lindner to manufacture the shredder components highly productively, as the latest installation shows: The process designed by DMG MORI Heitec includes two DMU 80 P duoBLOCK machines with WH Flex.

Circular economy for plastics

Turnkey system solutions from Lindner for plastics recycling are very much in vogue. A functioning circular economy can only be realized with high-quality recycled material. The right raw material is required for this. In order to be able to produce this profitably at the lowest possible cost, Lindner offers a full range of modern shredders as well as washing and sorting components from a single

source. Enabling recycling of materials is a major priority in politics, business and society, but the processes of material preparation need to be economical and automated.

Mono-Fix – flexible cutting system for shredding plastics

Choosing the right cutting system depends on the type of plastic. Different knife systems have to be used, as the interaction of

INNOVATIVE SHREDDING TECHNOLOGY FOR RECYCLING

rotor, stator knives and speed has a significant influence on the quality of the shredded plastic. In addition, knife systems are subject to continuous wear.



3. Mono-Fix holder and knife insert for a Micromat shredder.

»

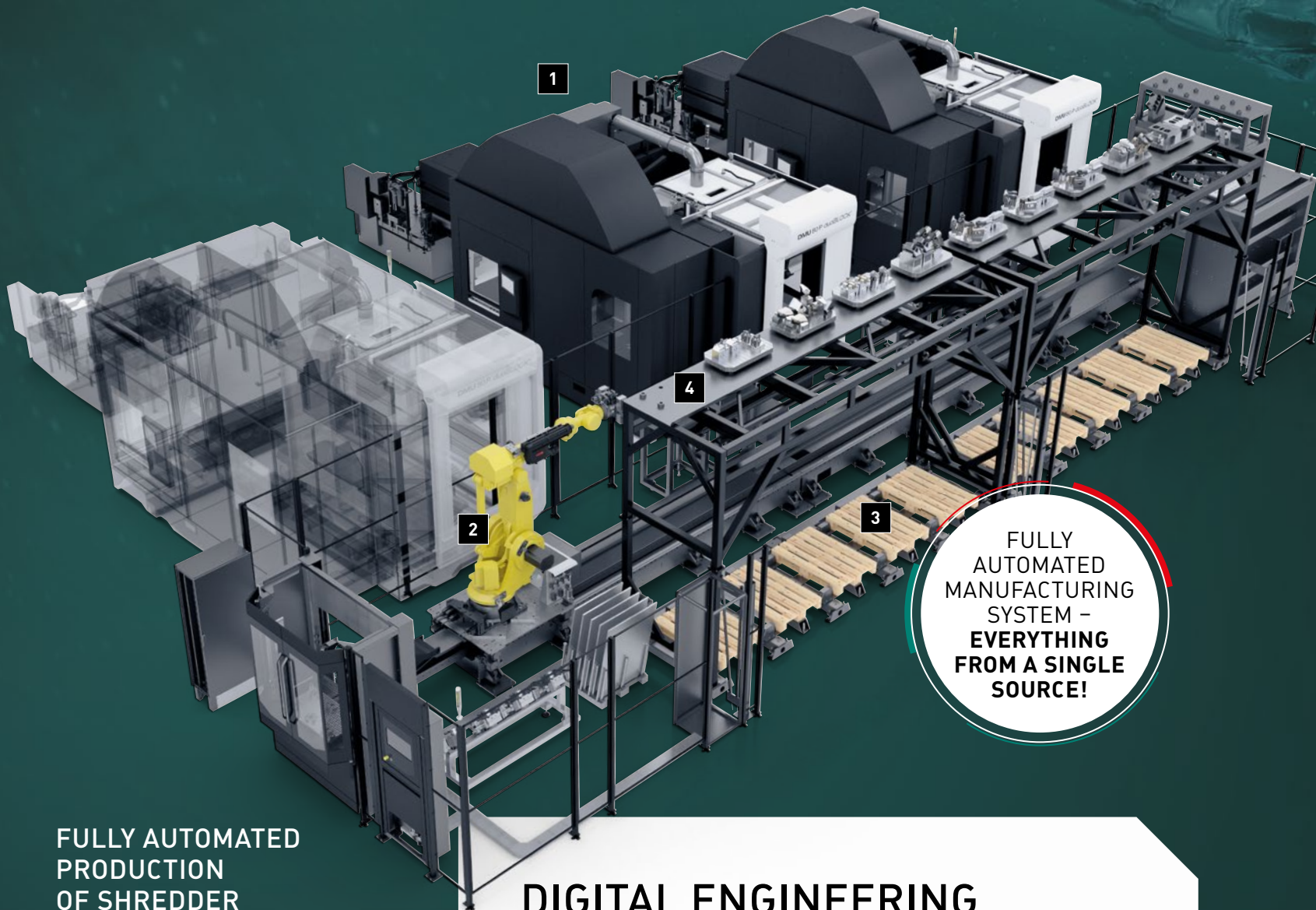

FULLY
AUTOMATED
MANUFACTURING
SYSTEM –
EVERYTHING
FROM A SINGLE
SOURCE!

FULLY AUTOMATED PRODUCTION OF SHREDDER COMPONENTS

1. 2×DMU 80 P duoBLOCK machines, expansion with a third machine possible
 2. Mobile robot with 360 kg payload for loading the machines with raw material and automatic fixture exchange
 3. Pallet store with space for 8 Euro pallets for storage of bulk goods, various fixtures and workpiece grippers
 4. Storage for various fixtures and workpiece grippers
- + Cleaning station, SPC and NOK drawer etc.

DIGITAL ENGINEERING

THE RESOURCE-CONSERVING SOLUTION FOR PRODUCTION START-UP AND TEST MACHINING

The most efficient machines are those that produce around the clock. This is where the advantages of digital engineering lie. The machine or the entire system is completely simulated digitally in advance, including all of the program and automation. This eliminates the extremely time-consuming and resource-intensive running-in of the actual machine. New processes can also be set up digitally while the machine is still running.

- + **40 % faster production ramp-up** – carry out employee training and non-productive activities digitally
- + **Up to 30 % cost reduction** – less testing on the machine
- + **100 % collision-free run-in** – complete digital testing and optimization

Lindner developed the smart Mono-Fix system to meet this challenge. Mono-Fix allows knives and knife holders to be changed with just a single screw. This minimizes downtime during maintenance. Different pointed and flat knives, blanking plates and special counter knives that can be used on the same rotor body are available. This makes it possible not only to completely replace the cutting system when it is worn, but also to use different or mixed rotor configurations.

Two DMU 80 P duoBLOCK machines with WH Flex – fully automatic manufacturing of shredder components

Because of the considerable increase in demand for recycled materials and the necessary variety of shredding systems, Lindner requires fully automated production of the Mono-Fix system. For this purpose, DMG MORI has supplied 2x DMU 80 P duoBLOCK machines, which are loaded and unloaded by the mobile robot of the WH Flex. The raw material for the knife and knife

holder is supplied in bulk via commercially available Euro pallets. The robot picks up a workpiece using camera recognition (bin picking). Various grippers and fixtures are available that can be changed automatically. The fully automated manufacturing system, including process design and programming, was supplied by DMG MORI Heitec. The system is planned in such a way that it can be extended with a third DMU 80 P duoBLOCK.

Digital engineering for virtual testing and optimization

Another highlight is digital engineering. While the actual system is still under construction, the full functionality of the digital system can be used for training employees or for planning, programming and simulating forthcoming tasks. All processes can be tested and optimized virtually. On day 1, all that is required is to connect the power and press the start button.

LINDNER RECYCLINGTECH FACTS

- + Established in 1948
- + More than 350 employees worldwide
- + 3 production sites in Austria
- + Export to more than 90 countries

LINDNER

Lindner-Recyclingtech GmbH
Villacher Straße 48
9800 Spittal/Drau, Austria
www.lindner.com



CIRCULAR ECONOMY



**OUR GUARANTEE:
OUR MACHINES ARE > 99% RECYCLABLE****

- ✓ Our contribution to the sustainability of your production:
 - + Production of the machines is 100% climate neutral – from raw material to delivery*
 - + Complete avoidance of waste at the end of the machine life cycle: >99% recyclable materials**
- ✓ **DMG MORI certificate** for customers, auditors and waste disposal companies
- ✓ **Valid for all existing and new machines**

* with the triad of "Avoid. Reduce. Compensate."
** apart from a few plastics

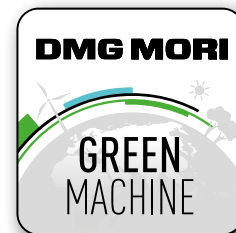

100% CLIMATE-NEUTRAL MACHINE MANUFACTURING

1. Neutral product carbon footprint upstream*
2. Neutral company carbon footprint
3. Machines up to >99% recyclable

NEW: DMG MORI CELL CONTROLLER LPS 4

HIGHLIGHTS LPS 4

- + Pallet, workpiece & tool handling
 - + Tool management
 - + Fixture management
 - + AGV control
 - + ISTOS PRODUCTION PLANNING & CONTROL
 - + CELOS Job Manager
 - + Reporting & evaluation functions, e. g. OEE
- >> Modular software modules exactly adaptable to any customer requirement

LPS 4 –
ONE MASTER
CONTROL FOR ALL
AUTOMATION
SOLUTIONS

WORKPIECE HANDLING

TOOL MANAGEMENT

PALLET HANDLING

AGV CONTROL

CONNECTIVITY
by DMG MORI



Everything
from a single
source from
DMG MORI.

FOR CPP, LPP, MATRIS,
WH Flex and AGV's
(PH, WH & TH)
and combinations thereof.

The new DMG MORI Cell Controller LPS 4 combines everything in one. From pallet handling to workpiece handling, up to the control of AGVs. Thanks to DMG MORI Connectivity with direct interfaces to CELOS, ISTOS PRODUCTION PLANNING, your ERP system and tool management.



Michael Trenkle
Head of Special Design
DECKEL MAHO Pfronten GmbH



Ryotaro Hattori
General Manager
Automation System Department
DMG MORI Co. Ltd., Nara

Clear display of machines, setup stations and system status, incl. manual manipulation options in the process, e.g. pallet transports.

| Priority | Job Name | Progress | Order Name |
|----------|-------------|----------|-------------|
| 2 | A11086C07A2 | | 9999 |
| 2 | A11086C07B2 | | 9999 |
| 2 | A11086C07C2 | | 9999 |
| 5 | 5BH8163214B | | TF013544 |
| 7 | A03439C03A | | TG018137 |
| 8 | A03439C03B | | TG018137 |
| 9 | A03447B03B | | TG002026 |
| 9 | A03447B03A | | TG010914 |
| 11 | A00655D06A | | TG005831 |
| 12 | A08707B08A | | TG008887 |
| 13 | A08814D02A | | TG010268 |
| 14 | A11086C07B | | TF022489 |
| 14 | A11086C07C | | TF022490 |
| 14 | A11086C07A | | TF022488 |
| 15 | S136316 | | Order202007 |

| Date & Time | Event Name | Event Message |
|---------------------|---------------------------------|--|
| 2020/07/30 12:29:46 | Operation mode changed | System operation mode changed from manual to automatic |
| 2020/07/29 14:37:55 | Switch to offline | |
| 2020/07/29 14:37:55 | Manual pallet transfer complete | Sent from [36], to [1] Pallet [5] |

PRODUCTION PLANNING

- + Production & resource planning of all jobs
- + Interface to ISTOS PRODUCTION PLANNING & CONTROL
- + Standardized ERP interface (individual adjustments may be necessary)

SET-UP MANAGER

- + Creation of individual jobs
- + Access to resource database, e.g. fixtures and tools

JOB MANAGER

- + Management of all jobs in the whole system: Individual jobs/jobs with multiple stations/job families
- + Interface to CELOS Job Manager

REPORTING

- + Detailed reporting on job, & machine level/total plant/tools, etc.
- + OEE evaluation



The introduction of TULIP allowed us to sustainably optimize the entire manufacturing process. From PRODUCTION PLANNING to material management to actual assembly. Better than with any ERP system.

Sven Donner
Production manager at VETEC Ventiltechnik GmbH,
now Project Director at SAMSON AG



PAPERLESS DOCUMENTATION

ACROSS THE ENTIRE VALUE-ADDED CHAIN

VETEC Ventiltechnik GmbH develops and manufactures rotary plug valves, pneumatic actuators and customized valves for industrial applications. The Speyer-based control technology specialist is a subsidiary of SAMSON AG, with headquarters in Frankfurt am Main. VETEC has been setting standards in solving valve control problems in most industrial areas for four decades – from the oil and gas industry to refineries in the petrochemical sector to large-scale chemical

plant and in the metal, paper and food industries. Among other machines, VETEC uses an NLX 3000|700, a DMU 100 monoBLOCK and an NHX 8000 from DMG MORI so that it can continue to manufacture the steadily growing product range economically. VETEC also digitizes various processes in the value-added chain with the help of the TULIP no-code platform.

Digital and paperless process support with TULIP

In order to modernize its production facilities, VETEC relies on digital solutions such as myDMG MORI for accelerating service as well as TULIP in the area of individually created apps for paperless documentation across the entire value-added chain. "It starts with the control of production orders," explains Sven Donner: "For example, the TULIP app manages parts



The assembly team receives specific assembly instructions via a TULIP app so that every assembly can be put together correctly.

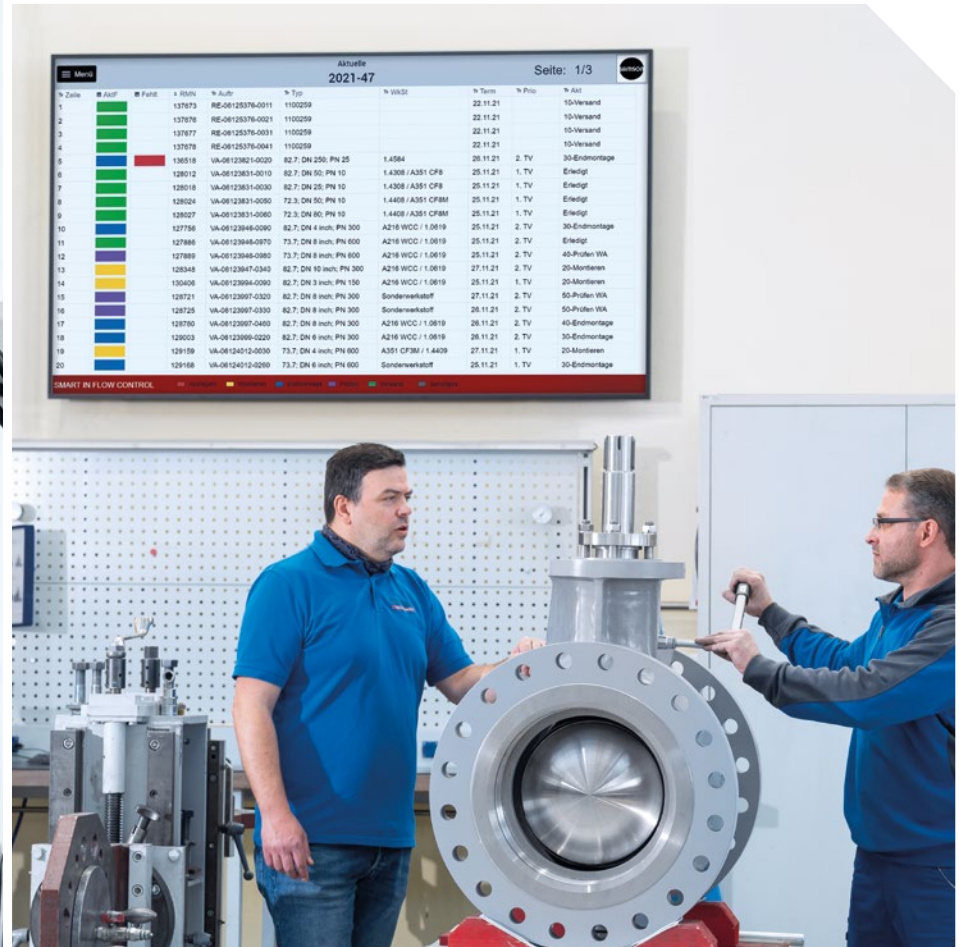

In another app, TULIP displays all customer orders including their respective status within a calendar week.

lists with outstanding reliability, something that in paper form can lead to errors." TULIP displays all customer orders including their respective status within a calendar week in another app. "To date, no ERP system has succeeded in replicating this."

Optimized assembly and quality assurance with TULIP

A look at the assembly of the fittings reveals the extensive variety of potential TULIP applications. "The team receives specific assembly instructions via a TULIP app, meaning that each assembly is reliably put together," explains Sven Donner. This also includes documenting leakage values and seat corrections. "In the past, it was virtually impossible to evaluate such data in paper form." The digital process makes continuous analysis and optimization possible. "This increases the quality considerably." VETEC has also implemented an intelligent control system

for defective parts with the help of TULIP, as Sven Donner adds: "It is important for all of the required components to be available from our own production as well as from third-parties so that assembly doesn't grind to a halt." These examples are only part of what VETEC has transformed into a paperless process with TULIP. "Leakage logs and pressure testing are also supported with TULIP apps and we will certainly be looking into other potential uses in the future."

Thinking Big – rotary plug valves up to DN700

"Increasingly, global markets are demanding valves with larger flow cross-sections," says Sven Donner, Project Director at Samson. The product range manufactured so far in nominal sizes from DN25 to DN500 therefore had to be expanded quickly to fulfill customer requirements. In-house market research by VETEC revealed that the development of two

new rotary plug valves with nominal sizes of DN600 and DN700 is essential for maintaining competitiveness.

NHX 8000 – high-power machining with 1,400 Nm

For VETEC, this meant extending machining capacity within a year in parallel with the development of the two new valves. The main focus was on a classic 4-axis horizontal machining center with the option of an interchangeable U-axis. The strength of the new acquisition needed to be significantly more in the area of high-power than in high-speed cutting, the reason being the numerous difficult-to-machine materials that have to be processed, such as Hastelloy, Monel, Duplex, Super Duplex, Stellite and zirconium.

»

PRIME EXAMPLE OF HOW MACHINE BUILDERS, TOOL MANUFACTURERS AND END USERS HAVE TO WORK TOGETHER.

“We machine these in the Speyer plant up to a maximum workpiece weight of three tons,” adds Sven Donner. Consequently the NHX 8000 with the 1,413 Nm powerMASTER spindle was added to the shortlist.

At the beginning of 2019, VETEC decided to buy the NHX 8000, which was put into operation in the same year. Since a U-axis is useful for certain turning operations on the valve housing, actuating tool specialist KOMET was involved in the planning at an early stage.

During the production phase, DMG MORI was able to prepare the machine hardware for subsequent integration of the KOMET actuating tool. Sven Donner states: “For me, that was a prime example of how machine builders, tool manufacturers and end customers have to work together.” VETEC manufactured the first valve housing of nominal size DN500 from stainless steel [1.4408] on the NHX 8000 at the end of February 2020, i. e. from start to finish in a single clamping.

VETEC VENTILTECHNIK FACTS

- + Established in Speyer in 1900, the company has been a subsidiary of SAMSON AKTIENGESELLSCHAFT since 1988
- + 130 employees
- + Development and production of rotary plug valves, pneumatic actuators and customized valves for industrial applications



VETEC Ventiltechnik GmbH
Siemensstraße 12
67346 Speyer, Germany
vetec.samsongroup.com



«

Among other things, VETEC manufactures rotary plug valves in nominal sizes of up to DN700 (ø700 mm internal pipe diameter) for use in process or plant engineering, for example.

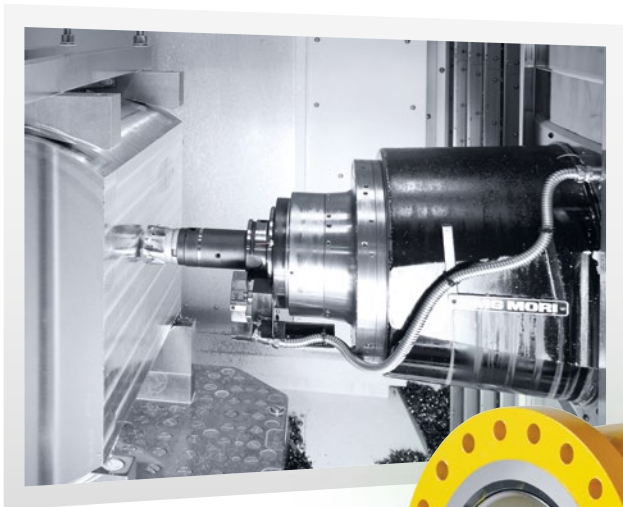

With a maximum torque of 1,413 Nm, the powerMASTER spindle of the NHX 8000 is perfect for heavy-duty machining.



Integrated noise attenuator that minimizes control valve noise emission, which is normally caused by the free jet flowing through the vena contracta.



NHX 8000

HIGH-POWER CUTTING WITH 1,400 Nm

- + Pallet size of 800 × 800 mm
- + Workpieces up to $\varnothing 1,450 \times 1,450$ mm and 3,000 kg
- + powerMASTER spindles up to 16,000 rpm or 1,413 Nm
- + Tools up to $\varnothing 320 \times 800$ mm and max. 30 kg
- + Maximum rigidity due to solid machine bed and 3-point support
- + CELOS with MAPPS

DMG MORI
TECHNOLOGY PARTNER
FUCHS

Tested, approved and used by DMG MORI

FUCHS IDM metalworking fluids and IDM greases are used in addition to our spindle oils in tough production use at DMG MORI every day. You too can rely on original quality. Put your trust in FUCHS.
www.fuchs.com/de/en

LUBRICANTS. TECHNOLOGY. PEOPLE.
FUCHS

END-TO-END BIDIRECTIONAL ACCESS TO THE PROCESS CHAIN

Complex components made of steel, titanium or aluminum are one of the core competences of NASHERO, which also manufactures molds for carbon fiber components.



Founded in 2009, NASHERO designs, develops, produces and sells light aircraft and aircraft components. At the same time, the company also uses its technical know-how to help customers that require high-precision and complex components for demanding industries, such as the medical sector. NASHERO uses machine tools from DMG MORI to efficiently manufacture such products, which are made of steel, aluminum, titanium or carbon fiber, amongst other materials. In 2017, the company installed an automated DMU 50 3rd Generation equipped with the Digital Manufacturing Package.

High-precision for the aerospace industry
Dr. Naresh Sharma dreamed of developing safe, efficient and faultless aircraft. "The development was based on our many years of experience in the aerospace industry," he says looking back to the early days. "The experience we gained showed us what beneficial and desirable safety features were needed." Today, the team has exceeded its initial dream. In addition to a light sport aircraft, the company also offers state-of-the-art production

technologies to OEMs in the aerospace industry. "We placed great value on keeping all processes in-house to ensure we had complete control over the quality of our work," explains Dr. Sharma. The requirements are extremely high, as NASHERO manufactures complex parts in small quantities and to tolerances right at the limit of the capabilities of the machine tools.

**Digital Manufacturing Package:
Any machine can be placed in a networked environment**

"The machine is one element in the process chain that achieves the required quality of the produced part. The machining strategy, tool holders, tools and their handling are just as important," says Dr. Sharma. "DMG MORI is one of the few that can make end-to-end and bidirectional access to the process chain possible." The DMU 50 3rd Generation is equipped with the Digital Manufacturing Package from DMG MORI, which can connect every machine in a networked environment: "Data is king in every company environment. Bidirectional data access in particular makes it possible

for us to work with maximum efficiency." The digitization solution gives the machines access to the company's ERP system and to

DIGITAL MANUFACTURING PACKAGE – DIGITAL NETWORKING OF EXISTING MACHINES

the data storage, which provides production with important data on tool, program and sub-routine.

Photos: Vincenzo Raeti



Data is king in every company environment. Bidirectional data access in particular makes it possible for us to work with maximum efficiency. And the Digital Manufacturing Package from DMG MORI allows us exactly this type of bidirectional access to the process chain.

Dr. Naresh Sharma,
 Founder and CEO of NASHERO,
 Ph. D. in Aerospace Engineering
 and Computer Sciences from TU Delft in 1997

Direct access to the machine

Programmers also have access to the same data and the ERP system from their workstations. They and the plant manager have access to the CELOS panel of the machine tool via the VNC protocol from their own workstations. This connection enables the team to perform simulations both in NX CAM as well as at the machine – even from the programmer’s workstation. The part program is then released for production if it passes the simulation.

Real-time data from the machine tool sensors

Alongside this bidirectional access, the Digital Manufacturing Package also offers other benefits that optimize day-to-day tasks at NASHERO. “The digital solutions provide status and process data from most of the machine tool sensors almost in real time,” adds Dr. Sharma. The status of the program sequence is also displayed through the Digital Manufacturing Package. DMG MORI Messenger provides a detailed overview of the machine at all times.

NASHERO uses the digitization solutions from order entry through to its completion. “We have integrated our internal ERP system into the process chain, from creation of the quote through first article inspection right up to inline quality control and input of the finished parts into our ERP system.”

Automation and digitization solutions for the future

Dr. Sharma is confident that with the DMU 50 3rd Generation and the Digital Manufacturing Package, DMG MORI products will continue to play an important role in future acquisitions: “As we are a technology-oriented company, we plan to continue to invest in high-precision machines.” The digitization and – depending on developments in the market – automation solutions will also be an important factor. “We are expecting double-digit growth once the current COVID-19 pandemic is over.”

NASHERO SRL FACTS

- + Founded in 2009 in San Giovanni in Croce
- + Development and production of light aircraft and aircraft components
- + Manufacturing service provider in the area of high-precision aerospace and defense components



Nashero Srl
 Via Delmoncello, 28
 26037 San Giovanni in Croce (CR)
 Italy
www.nashero.com



FUTURE-PROOF WHEEL MANUFACTURING



DMG MORI is an important partner for us. The wide range of products, the automation solutions from a single source and the focus on further digital developments make us optimistic that we can continue to implement innovative manufacturing processes.

Andreas Löhmann, Production Manager and
Philipp Hüsch, Tool Management at
Karl Georg Stahlherstellungs- und Verarbeitungs GmbH



Karl Georg specializes in the production of large wheels and wheel sets up to $\varnothing 1,250$ mm, which are used in cranes and crane trolleys, for example.

The history of Karl Georg Stahlherstellungs- und Verarbeitungs GmbH started in 1925 with the repair and construction of agricultural machinery. The manufacture of crane wheels was added in 1966 – a production area that was moved to the current Ingelbach-Bahnhof location in 1968. Under the motto “Moving a lot together” and with 120 employees, today Karl Georg supplies well-known crane manufacturers, logistics companies and also plant and machinery manufacturers. In its 8,500 m² production facility, the company has relied on the latest CNC technology from DMG MORI since 1980. A total of 13 machine tools are installed, including a DMC 80 FD duoBLOCK for milling/turning, four NLX turning centers and a CTX beta 1250 TC with Robo2Go for turning/milling. Digital solutions – exclusive DMG MORI technology cycles such as gearSKIVING 2.0 and the Digital Manufacturing Package – are also being used with increasing frequency.

Complete machining of 2,500 wheels per month

“Up to 2,500 wheels leave our manufacturing facility every month,” says Andreas Löhmann, Production Manager at Karl Georg, giving an insight into the everyday business

of the experienced workforce. A high degree of vertical integration from turning, milling and drilling to gear cutting and painting, and also the outstanding qualifications of our specialists, allow us to react flexibly to customer requirements at any time. In order to make sure that it stays that way, Karl Georg regularly takes on trainees and attaches great importance to giving staff further training, for example in courses at the DMG MORI Academy. The company ensures that it has efficient, quality-oriented manufacturing processes by investing regularly in production plant.

NLX 4000 – heavy-duty machining of workpieces up to $\varnothing 500$ mm

The range of components at Karl Georg mainly centers on rotationally symmetrical steel components in a wide variety of diameters and mainly in small series down to a batch size of 1. “This means we have to be able to react very flexibly in production,” says Philipp Hüscher, who is responsible for tool management at Karl Georg. The long-term cooperation with DMG MORI has resulted in the installation of four NLX turning centers since 2017 – one NLX 3000 and three NLX 4000s.

NLX 4000 BY | 1750

HEAVY-DUTY MACHINING WITH TORQUE OF 3,225 Nm

- + Box ways in all axes with optimum damping characteristics and dynamic rigidity
- + 1,500 rpm main spindle with 3,225 Nm
- + Workpieces with a diameter of up to 500 mm and a length of 720 mm
- + 185 mm spindle bore
- + 12-station BMT turret up to 10,000 rpm or up to 100 Nm
- + 120 mm Y-axis



Karl Georg uses WERKBLiQ and has networked the machines with the Digital Manufacturing Package in order to minimize downtime.

“We benefit from the stability of the NLX models for heavy-duty machining,” adds Andreas Löhmann. The compact design in relation to the 600 mm turning diameter in the larger model was also an argument in favor of using these machines.

DMC 80 FD duoBLOCK – mill-turn complete machining

Since 2021, Karl Georg has been using a DMC 80 FD duoBLOCK with a special chuck from Schunk for machining even bigger wheels up to $\varnothing 700$ mm. “The technology integration on the milling/turning center is a leap in innovation that allows us to completely machine large wheels,” explains Andreas Löhmann. The DMC 80 FD duoBLOCK also increases productivity because of its pallet changer: “Being able to set up while production is in progress increases the utilization of the machine considerably.”

CTX beta 1250 TC with Robo2Go: Automated turn-mill machining of medium-size batches

Karl Georg also achieves a high degree of machine utilization with an automated CTX beta 1250 TC. The turning-milling center was purchased for complete machining of series production parts. In this case, batch size is up to 20 parts. “An optimal volume for the Robo2Go,” thinks Philipp Hüsch. As the CTX beta 1250 TC operates autonomously for long periods, the operator can work in parallel on one of the NLX 4000 machines. Andreas Löhmann sees great potential in the automation of manufacturing processes and in multi-machine operation: “We are increasing our capacity and working much more efficiently with this approach.”

DMG MORI technology cycles: Complete machining including turning, milling and gear cutting

For complete machining, Karl Georg relies on turning and milling in a single clamping as well as on exclusive DMG MORI technology cycles for gear cutting. “We carry out hobbing on the CTX beta 1250 TC,” says Philipp Hüsch, quoting an example. gearSKIVING 2.0 is used on the DMC 80 FD duoBLOCK. “We are currently machining module 10 spur gears.” According to Andreas Löhmann, the company wishes to continue developing the use of DMG MORI technology cycles. “The more process steps we implement on a machine, the more effective we become.”

machine tools on the shop floor. “We use the DMG MORI NETservice so we can transmit technical problems live to the DMG MORI Service which helps us to keep machine downtime as short as possible,” says Philipp Hüsch. Many of the downtimes that occur can be discussed and rectified over the phone using this remote solution, which DMG MORI provides as part of the Digital Manufacturing Package.

Technology integration, automation solutions and digital processes – Karl Georg has found a way of making its production sustainable. Andreas Löhmann regards DMG MORI as an important partner: “The wide range of products, the automation solutions from a single source and the focus on further digital developments make us optimistic that we can continue to implement innovative manufacturing processes.”

INTO THE FUTURE WITH INNOVATION

Digital Manufacturing Package with NETservice: Short downtimes thanks to remote service

A basic requirement for high utilization of production capacity is highly reliable



In the event of service, Karl Georg uses the DMG MORI NETservice for faster error analysis.

KARL GEORG FACTS

- + Established in 1925, the company has manufactured crane wheels and wheel sets since 1966
- + There are 120 employees at the company's headquarters in the Westerwald area (Ingelbach-Bahnhof)
- + Worldwide supplier to well-known crane manufacturers, plant and machine constructors and operators



Karl Georg Stahlherstellungs- und Verarbeitungs GmbH
Bahnhof, Karl-Georg-Straße 3
57612 Ingelbach, Germany
www.karl-georg.de



DIGITAL MANUFACTURING PACKAGE

YOUR "MUST HAVE" FOR THE DIGITAL FUTURE
4 PRODUCTS – ONE PACKAGE – ONE PRICE

① SECURE CONNECTIVITY



BI
BEST OF INDUSTRY AWARD 2020 – Industry 4.0 category

③ CELOS V6 Update



④ NETservice + myDMG MORI

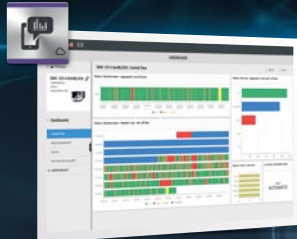

② MESSENGER



YOUR ONLINE SERVICE MANAGER

STATUS QUO:
> 30,000
 CUSTOMERS
> 140,000
 MACHINES

my DMG MORI
 The new customer portal for service optimization

MORE SERVICE

Fast support and live status of your service requests

MORE KNOWLEDGE

All relevant documents can be called up digitally

MORE AVAILABILITY

The direct line to a service expert with guaranteed prioritized processing, **registration in < 3 minutes**

Every customer benefits – at no extra charge:
 Already 30,000 registered customers with more than 140,000 machines!



YOUR HISTORY
 YOUR MACHINES
my DMG MORI
 CUSTOMER PORTAL
 YOUR DOCUMENTS
 YOUR SERVICE REQUESTS

*my DMG MORI is currently available in member states of the European Union, the UK, Switzerland, Norway, India, Mexico, Canada, the USA, New Zealand, Australia, Singapore and Malaysia.



You too can benefit!
 Register now for free:
myDMGMORI.com

SAVE THE DATE
09.05. – 21.05.2022

OUR SHOWROOM
 IS ALWAYS OPEN FOR YOU –
 ALSO FOR SMALL GROUPS
 → Contact your DMG MORI representative



Experience DMG MORI live:
events.dmgmori.com

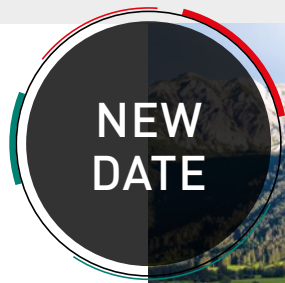

09. – 21.05.2022
DMG MORI
 OPEN HOUSE 2022
 PFRONTEN